

TECHNOGLASS®

Serie FLAT

Technische Informationen

Technical information

Informazioni tecniche

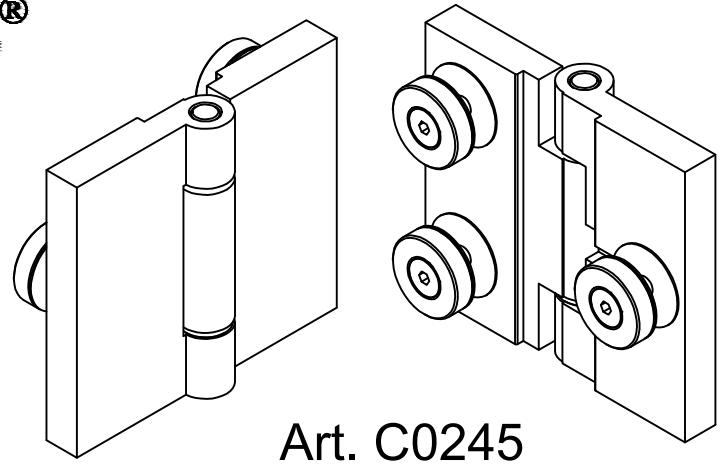

Art. C0245

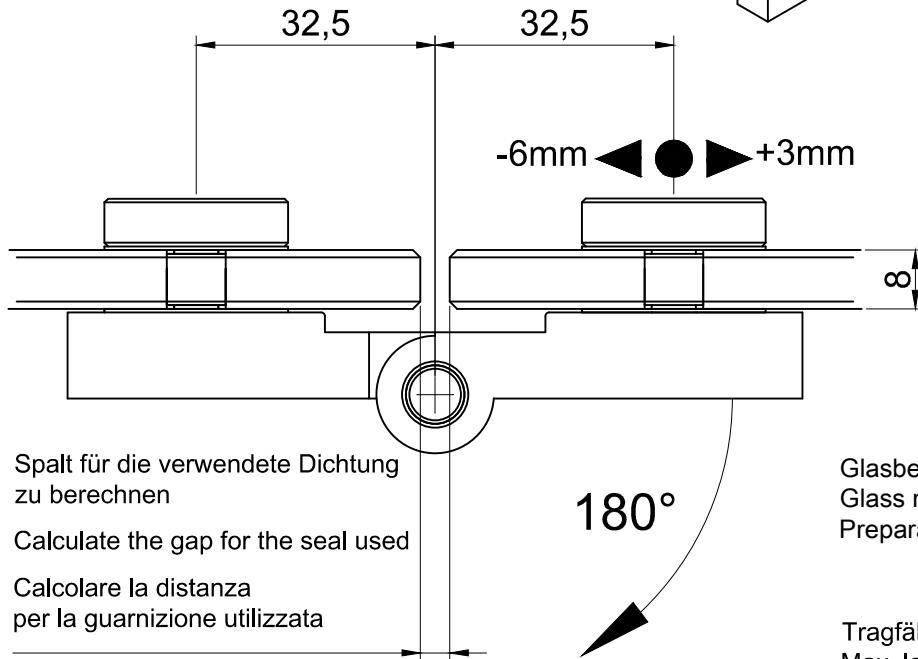

Spalt für die verwendete Dichtung zu berechnen

Calculate the gap for the seal used

Calcolare la distanza per la guarnizione utilizzata

Glasbearbeitung für
Glass machining for
Preparazione lastre

8mm

Tragfähigkeit, 2 Bänder
Max. loading weight, 2 hinges
Portata massima, 2 cerniere

40Kg

Maximale Türbreite
Max. Door width
Larghezza max. porta

900x1900mm

