

TECHNOGLASS®



AGGIORNAMENTO
CATALOGO

CATALOGUE
UPGRADE

BARRE DI STABILIZZAZIONE TRUMAN
SERIE TRUMAN SUPPORT BARS

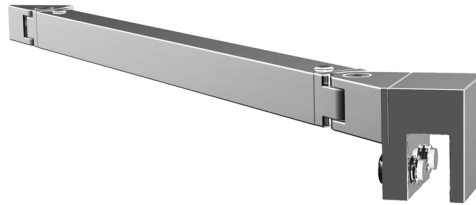
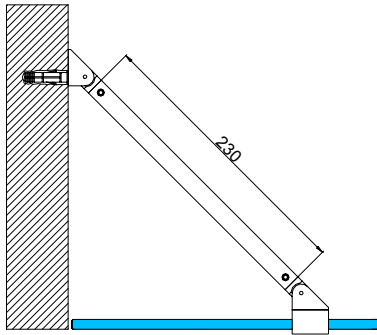

C0156

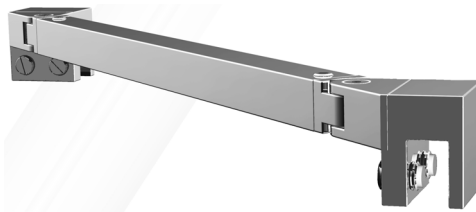
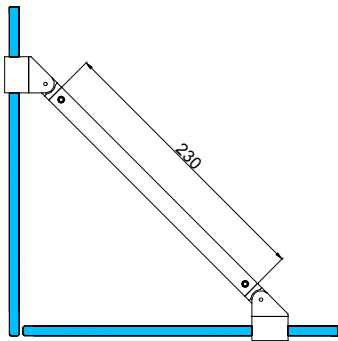

C0157

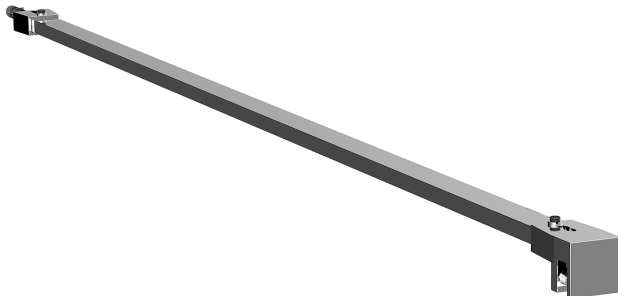

Fissaggio semplice per lastre ancorate a muro

Simple fixing for wall anchored glass panels

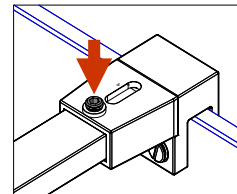

C0158 [L900]

C0159 [L1200]

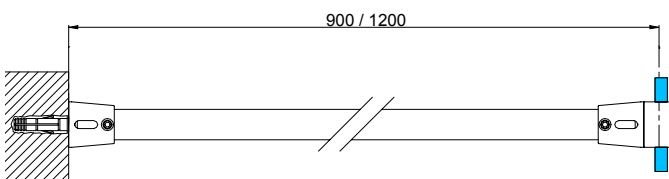

Portante per lastre non ancorate a muro

Safe fixing for free standing glass panels

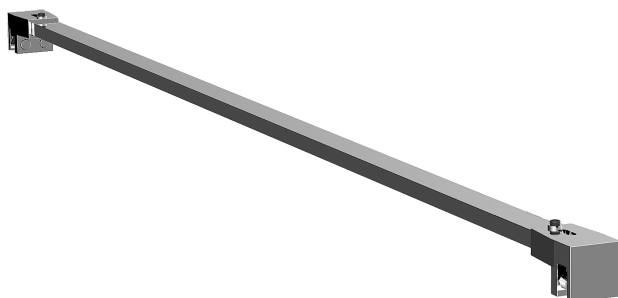
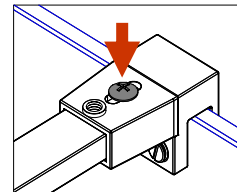

Fissaggio semplice per lastre ancorate a muro

Simple fixing for wall anchored glass panels

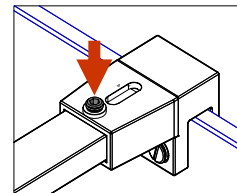

C0160 [L900]

C0161 [L1200]

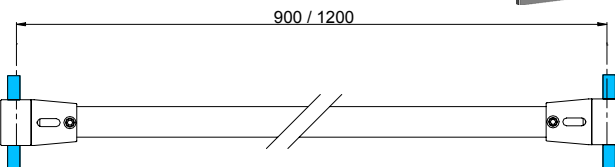

Portante per lastre non ancorate a muro

Safe fixing for free standing glass panels

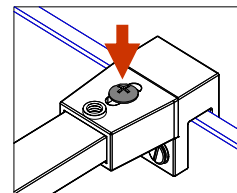

Art. C0158-159-160-161

Per misure inferiori tagliare il tubo.

Art. C0158-159-160-161

Pipe to be cut for shorter lengths.

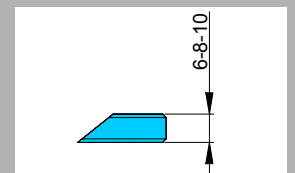

BARRE DI STABILIZZAZIONE "SLIM"
 "SLIM" SUPPORT BARS

C0166

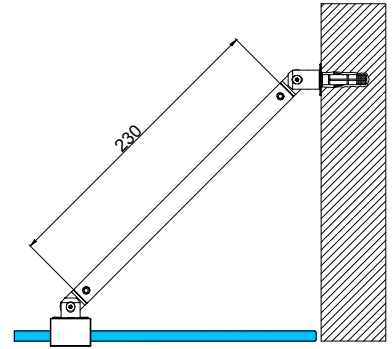

C0167

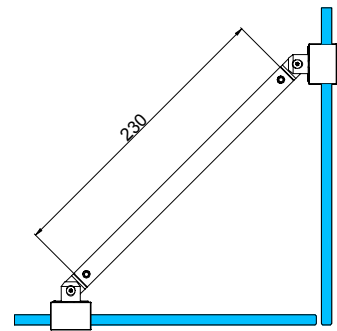

C0168 [L900]
 C0169 [L1200]

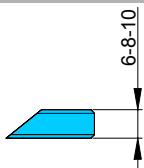
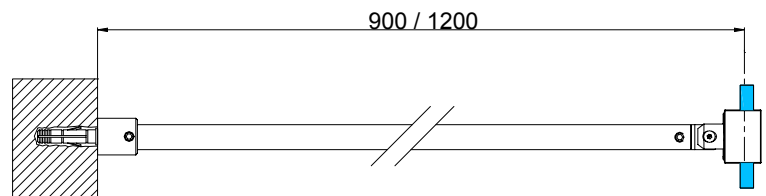
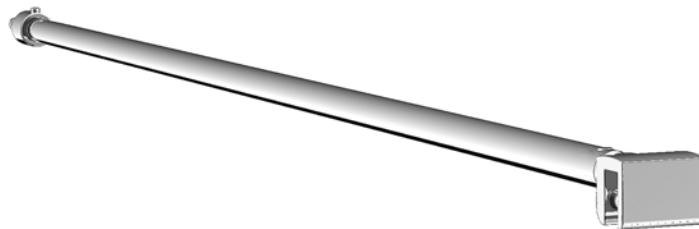

Art. C0168-C0169

Per misure inferiori tagliare il tubo.

Art. C0168-C0169

Pipe to be cut for shorter lengths.

BARRE DI STABILIZZAZIONE
SUPPORT BARS

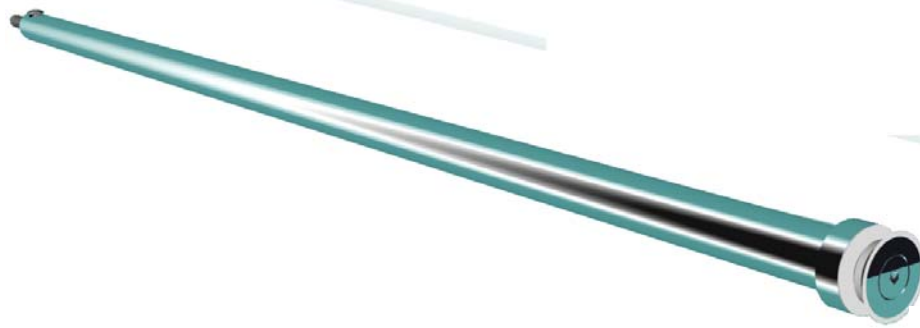

C0183 [L900]

C0184 [L1200]

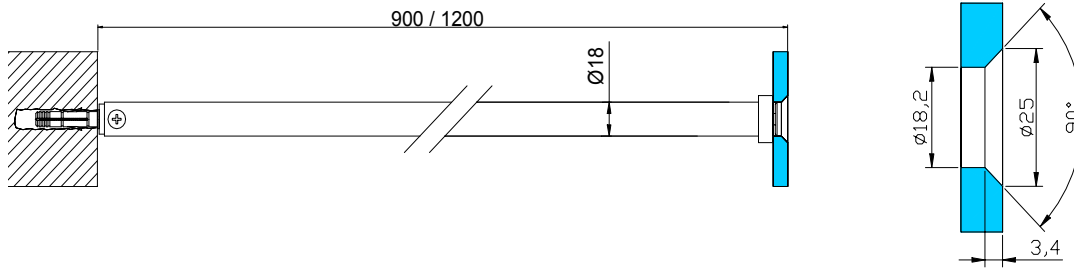

C0197
[L550÷800]

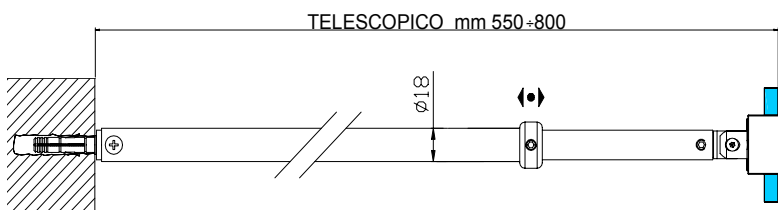

Art. C0183-184-197

Per misure inferiori tagliare il tubo.

Art. C0183-184-197

Pipe to be cut for shorter lengths.

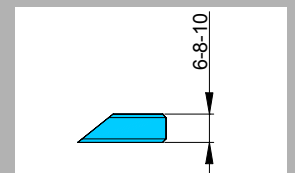

C0190

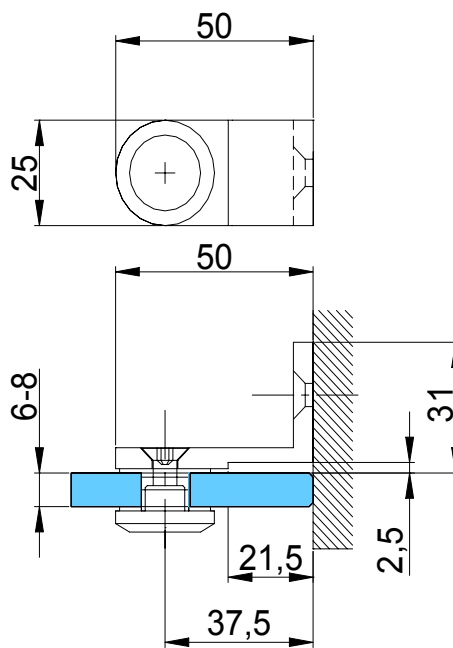

C0191

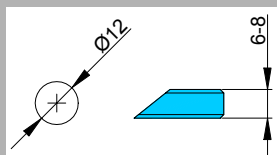
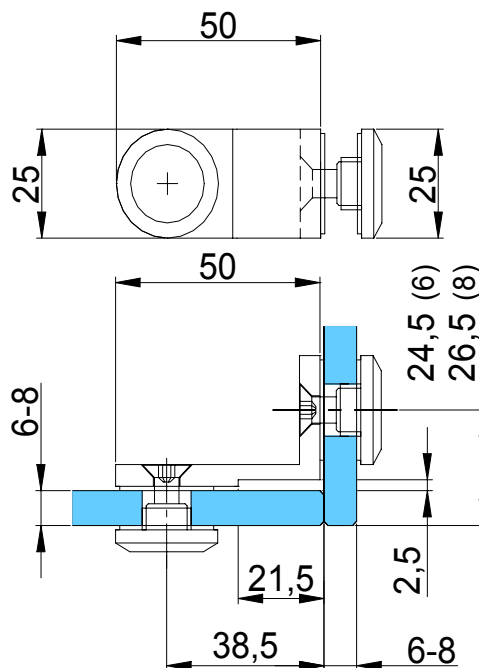
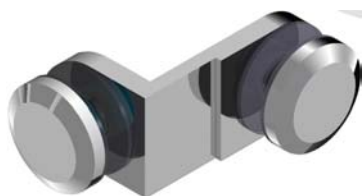

Calcolare la distanza fra le due lastre/ fra lastra e parete in base all'ingombro della guarnizione utilizzata.

Gap between the glass panels / glass panel and the wall to be calculated according to the size of the sealing profile used.

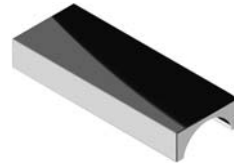
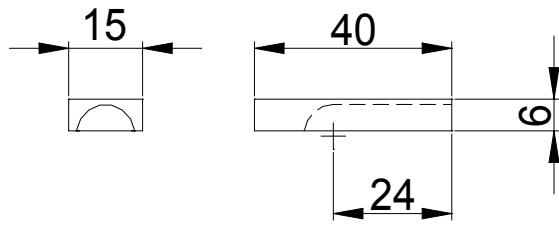
PROFILO SOTTOPORTA E RACCORDI
DOOR THRESHOLD AND JOINTS

M0210

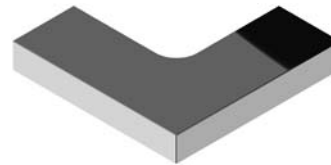
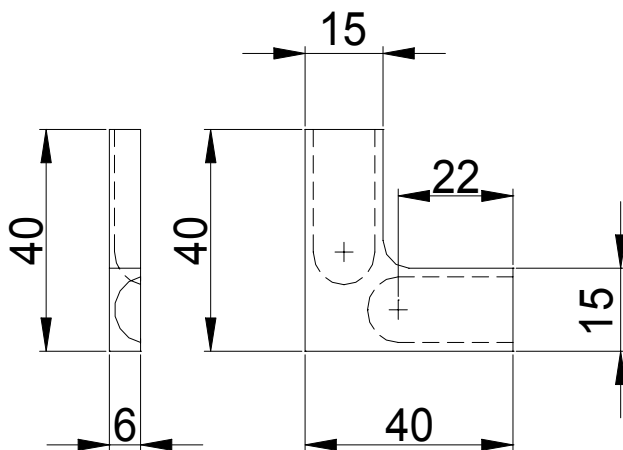

M0211

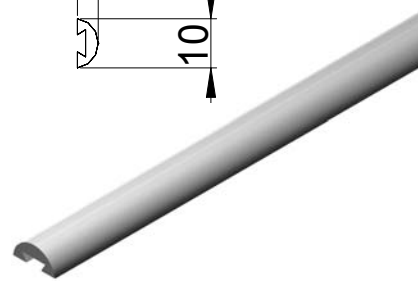
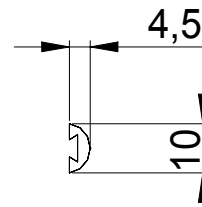
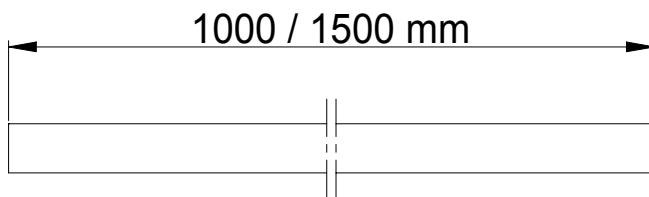

M0212 [L1000]

M0213 [L1500]

Profilo sottoporta in alluminio anodizzato da tagliare a misura e siliconare sul bordo del piatto doccia o sul pavimento. Raccordi coprifilo in alluminio cromato a siliconare.

Anodized aluminium door threshold to be cut and fixed by silicon on the shower tray or the floor. Terminal joints made of chromed aluminium, to be fixed by silicon.

SERIE FLAT

C0198

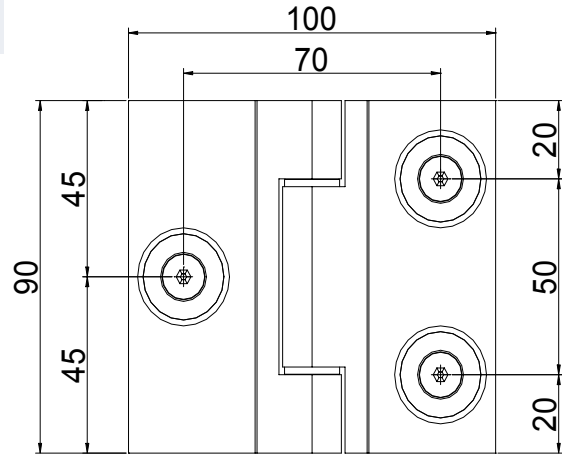
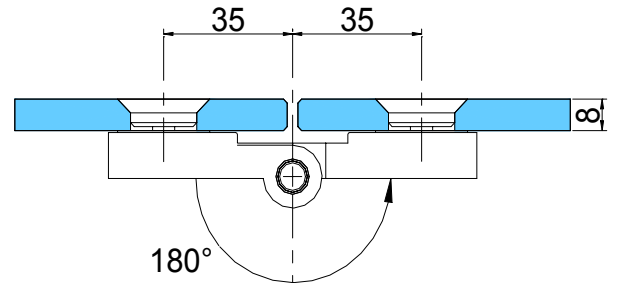
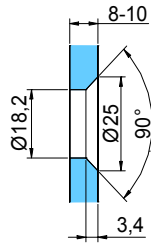
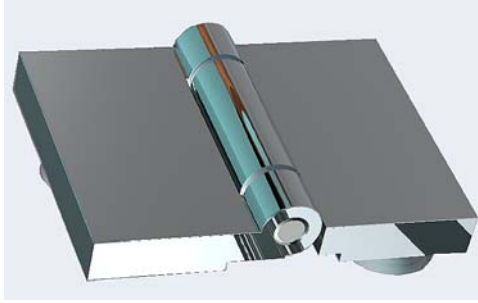

C0199

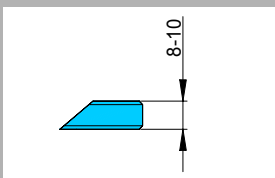
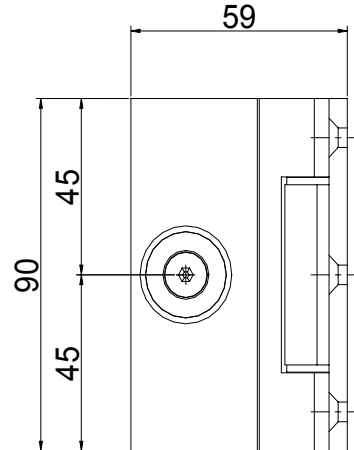
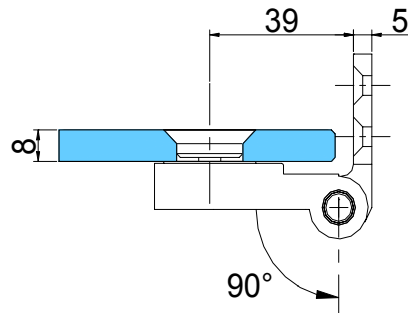
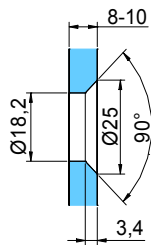
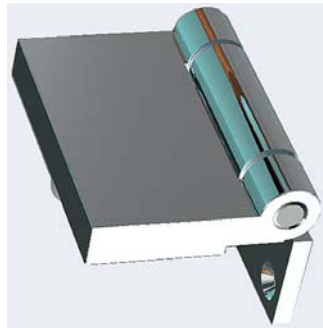

Cerniere con apertura libera esterna 180°
Fissaggio lastre con attacco filo-vetro

*180° outwards free swinging hinges
countersunk glass fixing point*



Calcolare la distanza fra le due lastre/ fra lastra e parete in base all'ingombro della guarnizione utilizzata.

Gap between the glass panels / the glass panel and the wall to be calculated according to the size of the sealing profile used.

MORSETTI PER VETRI FISSI
BRACKETS FOR FIX PANELS

C0185

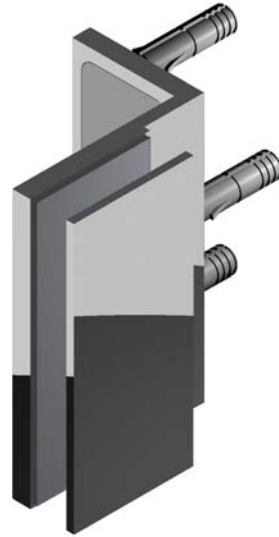
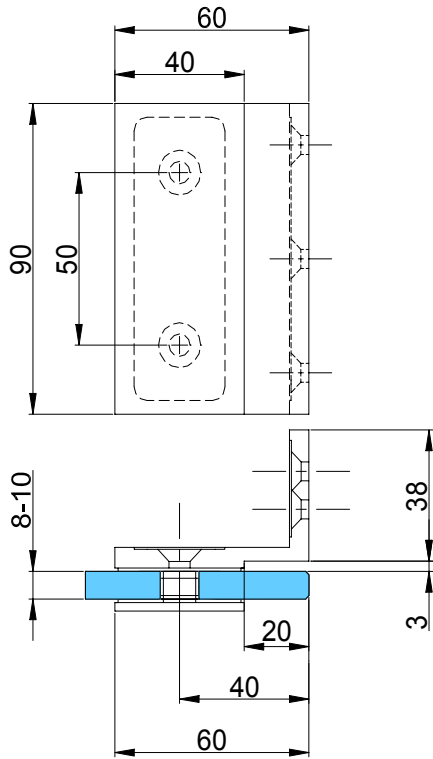

C0186

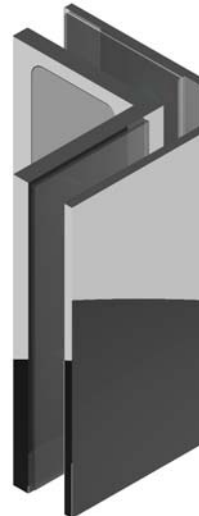
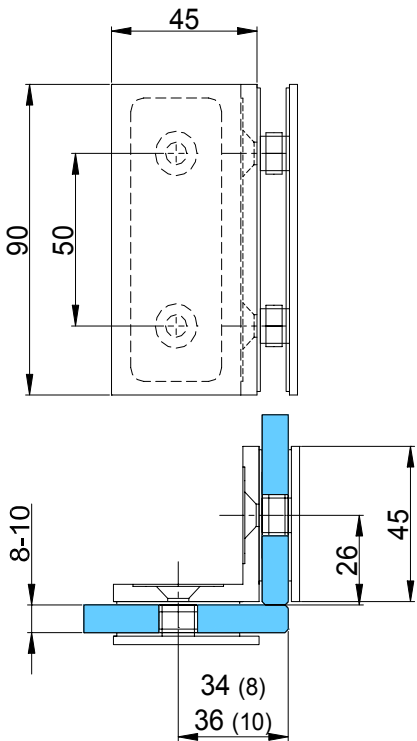

Calcolare la distanza fra le due lastre/ fra lastra e parete in base all'ingombro della guarnizione utilizzata.

Gap between the glass panels / the glass panel and the wall to be calculated according to the size of the sealing profile used.

I morsetti sono provvisti di placchette copriviti in acciaio inox.

Brackets supplied with stainless steel screws covering plates.

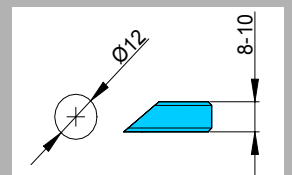

C0244

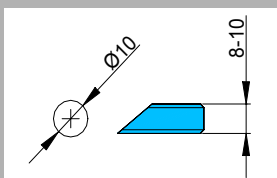
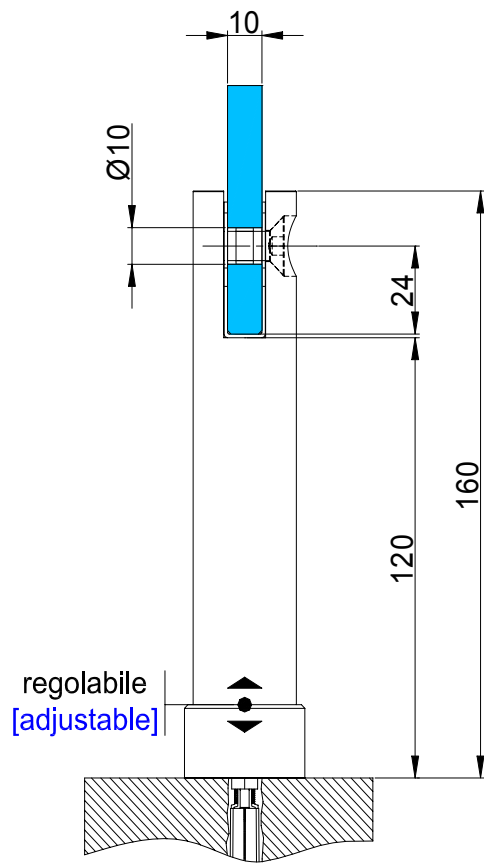

BARRE DI STABILIZZAZIONE
SUPPORT BARS

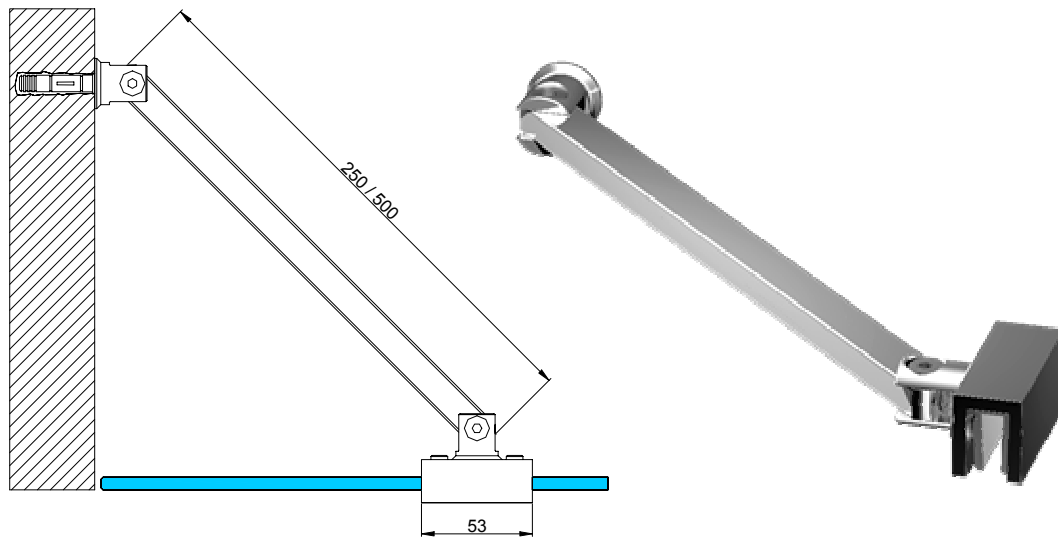

C0247 [L250]
C0248 [L500]
C0264 [L1000]

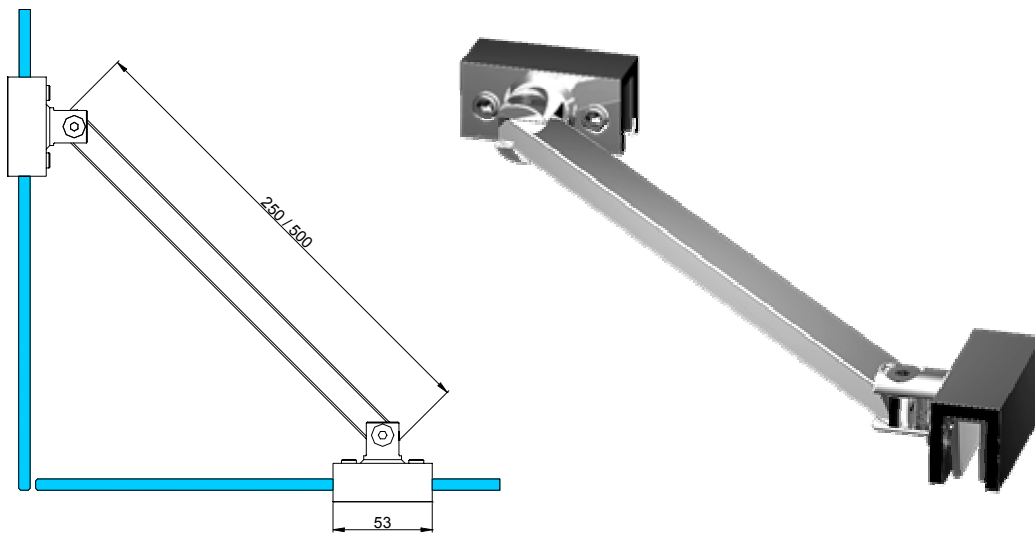
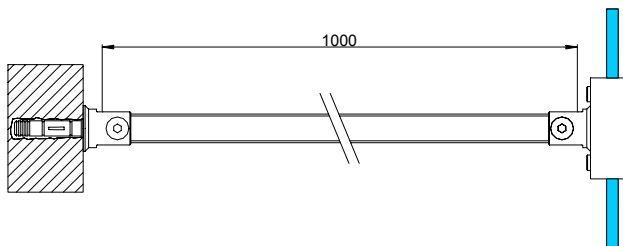

C0265 [L250]
C0266 [L500]
C0267 [L1000]

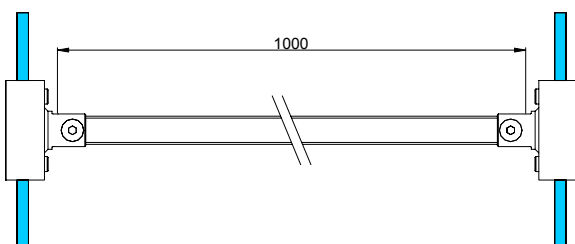

Art. C0247-248-264-265-266-267

Per misure inferiori tagliare il tubo.
Altre disponibili misure su richiesta.

Art. C0247-248-264-265-266-267

Cut the pipe for shorter lengths.
Other sizes available on request.

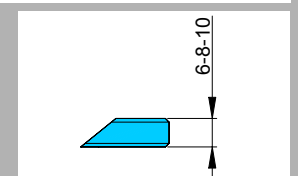



SERIE HAIKU

TECHNOGLASS®

SERIE HAIKU

C0260

Cerniera destra
Right hinge

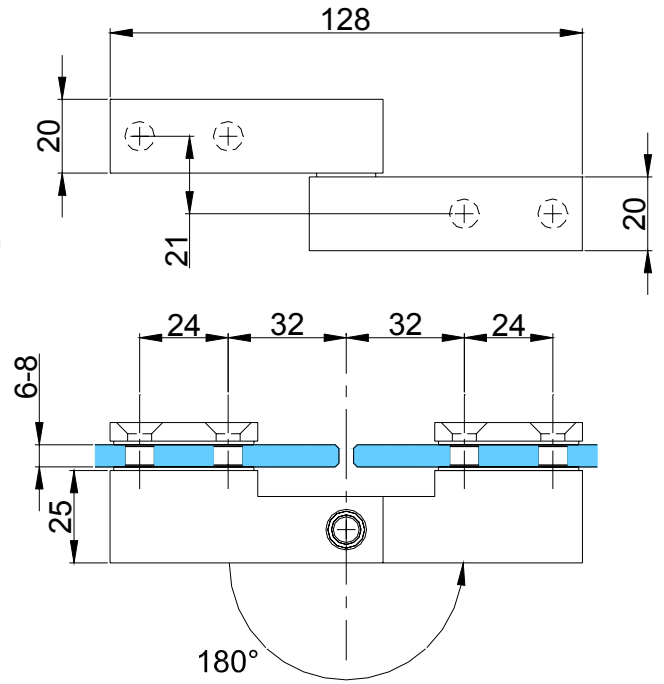

C0261

Cerniera destra
Left hinge

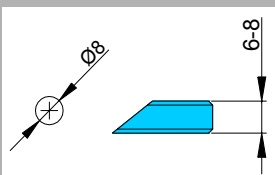
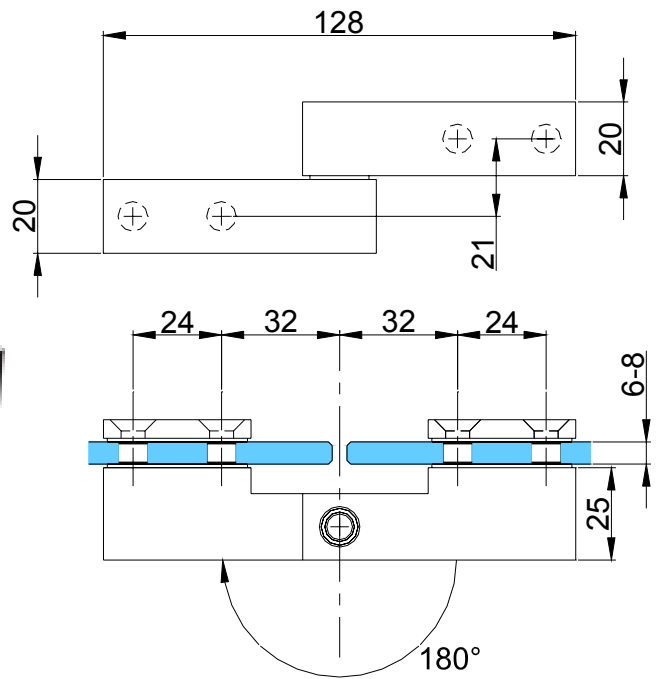
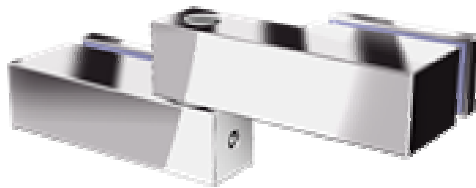



Calcolare la distanza fra le due lastre in base all'ingombro della guarnizione utilizzata.

Gap between the glass panels to be calculated according to the size of the sealing profile used.

TECHNOGLASS®

TABELLA PRINCIPALI MATERIALI E FINITURE DI SUPERFICIE

TABLE OF MAIN MATERIALS AND SURFACE FINISHES

ACCIAIO INOX STAINLESS STEEL		.A Lucido .A Bright .B Satinato .B Brushed
OTTONE BRASS		.C Cromo lucido .C Bright chrome
ALLUMINIO ALUMINIUM		.D Cromo satinato .D Brushed chrome
ZAMA ZAMAK		
OTTONE BRASS		.E Ottone lucido .E Bright brass .F Ottone satinato .F Brushed brass

Finiture diverse su richiesta.

Different finishes on request.

NOTE NOTES

Ogni informazione contenuta nel presente catalogo potrebbe subire modifiche o variazioni per motivi tecnici o commerciali, senza alcun preavviso da parte del costruttore.

Owing to commercial or technical reasons any information reported in this catalogue might be changed without previous notice by the manufacturer.

Si raccomanda di verificare sempre le quote sul prodotto fisico prima di praticare forature o tacche nel vetro.

We do recommend, drill holes or glass cutouts to be deduced by measuring the physical product always.

TECHNOGLASS®

Technoglass s.r.l.
Via A. Volta 53/a - 25065 Lumezzane (Brescia) Italy
Tel. +39 030 8971735 Fax +39 030 872537
e-mail: technoglass@smmoretti.it