

TECHNOGLASS®

**MANUALE GUIDA
ALL'UTILIZZO DI ACCESSORI TECHNOGLASS
PER CABINE DOCCIA SU MISURA**



SERIE 900

Questo manuale vuol essere una guida destinata a tutti gli Operatori specializzati del settore vetrario che si occupano della realizzazione e posa di cabine doccia in cristallo temperato su misura.

Scopo del manuale è quello di rendere quanto più semplice ed immediata la ricerca e selezione degli accessori Technoglass da parte degli Operatori interessati.

Per ogni linea di prodotto infatti sono previste e codificate le principali soluzioni applicative.

A ciascuna di esse corrisponde un kit base di accessori Technoglass, più alcune varianti tra cui è possibile scegliere. Ogni kit comprende tutti gli accessori necessari alla realizzazione della cabina doccia, con la sola eccezione del vetro, la cui preparazione è agevolata dagli schemi tecnici disponibili per ogni singola applicazione.

Qualora l'applicazione desiderata non sia prevista nel manuale, è possibile acquistare gli accessori Technoglass anche singolarmente o in combinazione con altri presenti nel manuale.

Technoglass si rende inoltre disponibile ad accogliere richieste specifiche per applicazioni personalizzate.

Le cerniere e/o sistemi di apertura e chiusura vengono sottoposti da Technoglass, in sede di pre-produzione seriale, a test funzionali che prevedono 20.000 cicli continuativi di apertura e chiusura secondo quanto previsto dalla normativa UNI-EN14428.

Vengono inoltre sottoposti a prove esasperate di carico al fine di verificarne la portata massima in condizioni estreme.

I trattamenti superficiali sono anch'essi testati in laboratorio affinché rispondano ai requisiti previsti dalla normativa in materia di accessori sanitari per l'ambiente bagno.

Tutti i prodotti inclusi nel presente manuale sono progettati e realizzati da Technoglass.
Sono pertanto di fabbricazione italiana.

Technoglass si riserva di modificare il contenuto del presente manuale in qualsiasi momento e senza preavviso alcuno.

Technoglass declina ogni responsabilità per installazioni eseguite in modo non corretto o per utilizzo improprio degli accessori inclusi nel presente manuale.

CONDIZIONI IDEALI PER LA POSA DI CABINE DOCCIA:

1) Condizione ideale per la realizzazione ed installazione di una cabina doccia è che il piatto doccia venga posato perfettamente piano rispetto al pavimento. I piatti doccia infatti non necessitano di alcuna inclinazione dato che la loro superficie interna ha già una propria pendenza, utile a favorire il deflusso dell'acqua in direzione del condotto di scarico.

2) In secondo luogo è importante che le pareti siano perfettamente a piombo e, nel caso di cabine ad angolo, perpendicolari fra loro.

ALCUNI CONSIGLI PER IL RILIEVO DELLE MISURE:

1) CABINE IN ANGOLO (PIATTI DOCCIA QUADRI O RETTANGOLARI)

Il rilievo delle misure deve essere effettuato su piatto doccia già posato. Evitare di affidarsi genericamente alle dimensioni del piatto (es. 75x75, 80x80) poiché, a seconda delle condizioni di posa (a filo oppure ad incasso rispetto al rivestimento delle pareti), la cabina potrebbe risultare troppo piccola o troppo grande.

Si consiglia pertanto di tracciare con del nastro adesivo il centro del bordo del piatto. Rilevare dunque la misura da filo rivestimento muro sino all'angolo di incontro dei due nastri (vedi fig.1). Le misure rilevate rappresenteranno l'ingombro totale della cabina doccia.

E' bene infine rilevare la perpendicolarità o l'eventuale fuori piombo delle pareti per tutta l'altezza della cabina desiderata. Può essere utile a tal fine costruire delle dime di cartone.

Con questi dati sarà semplice determinare la misura delle lastre, basandosi sugli schemi tecnici forniti in questo manuale.

2) CABINE IN ANGOLO (PIATTI DOCCIA TONDI O SEMI-TONDI)

Il raggio di curvatura dei piatti doccia tondi varia da piatto a piatto, da misura a misura. Gli accessori Technoglass sono idonei anche per l'utilizzo su vetri curvi, purchè questi ultimi conservino un lembo di superficie non raggiata per l'applicazione di cerniere o morsetti. E' fondamentale che il tratto di superficie ove andranno montate cerniere o morsetti sia perfettamente piano. Per la realizzazione di cabine con vetri curvi non è possibile installare il profilo di contenimento sottoporta (art. M0212 / M0213) con relativi terminali.

3) CABINE IN NICCHIA (PIATTI DOCCIA QUADRI O RETTANGOLARI)

Anche in questo caso il rilievo delle misure deve essere eseguito su piatto doccia già posato.

Si consiglia di tracciare con un nastro adesivo il centro del bordo del piatto. Rilevare dunque la misura da parete a parete (filo rivestimento) in tre punti:

- alla base, sul bordo del piatto doccia;
- a mezza altezza;
- ad altezza totale della cabina desiderata (normalmente 1800÷2000mm).

Anche in questo caso, in presenza di "fuori piombo" può essere utile preparare dime di cartone.

Le misure delle lastre si potranno facilmente derivare grazie agli schemi tecnici forniti in questo manuale.

fig.1

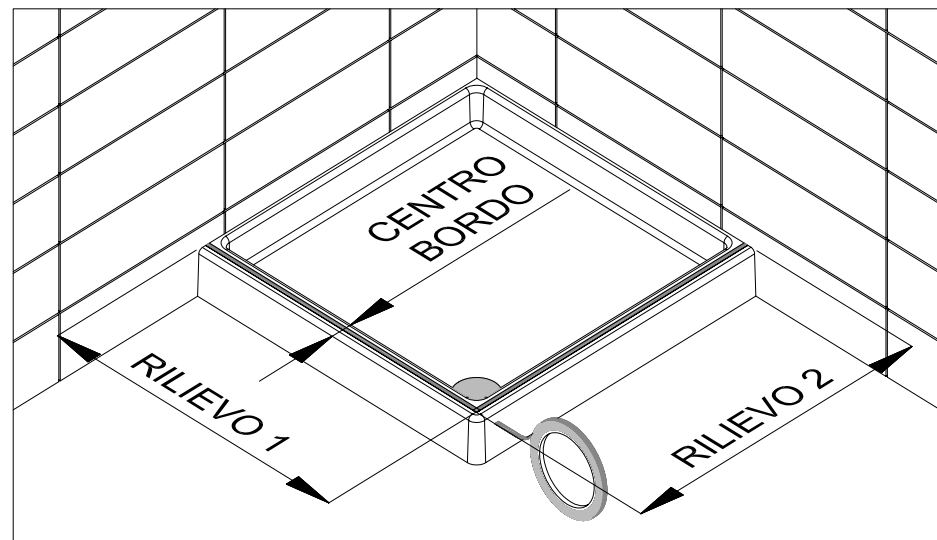

SEZIONE INTRODUTTIVA

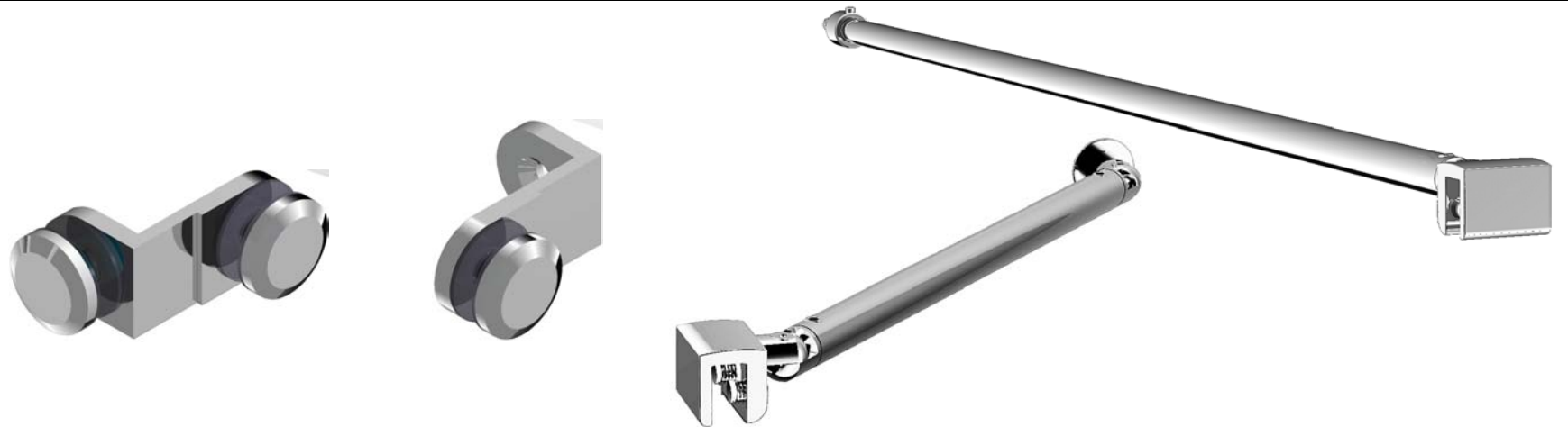

SERIE 900

APPLICAZIONI

A25

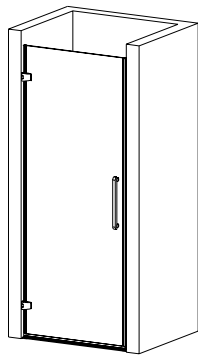

A26

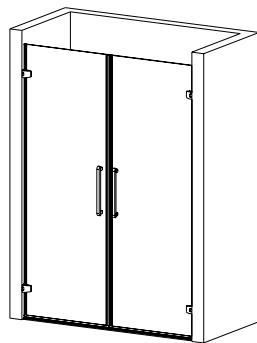

A27

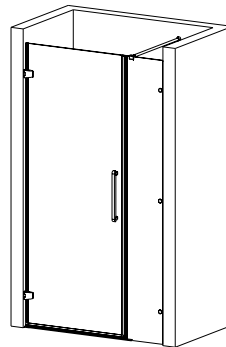

A28

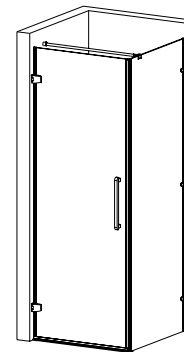

A29

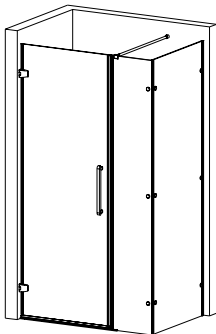

A30

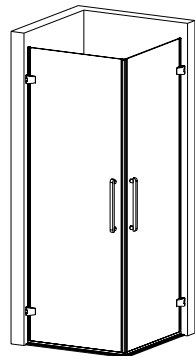

A31

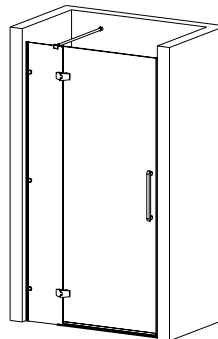

A32

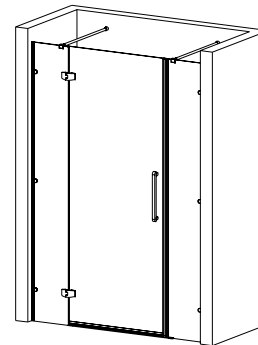

A33

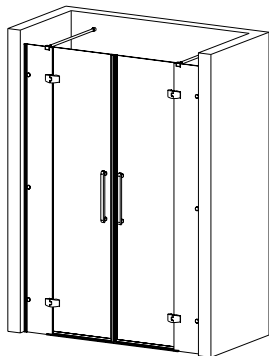

A34

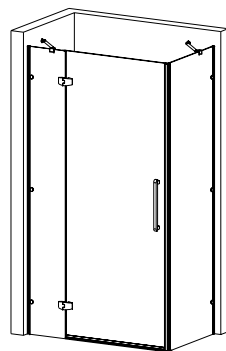

A35

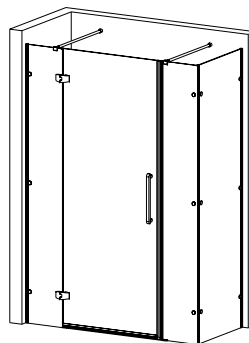

A36

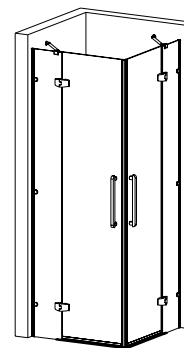





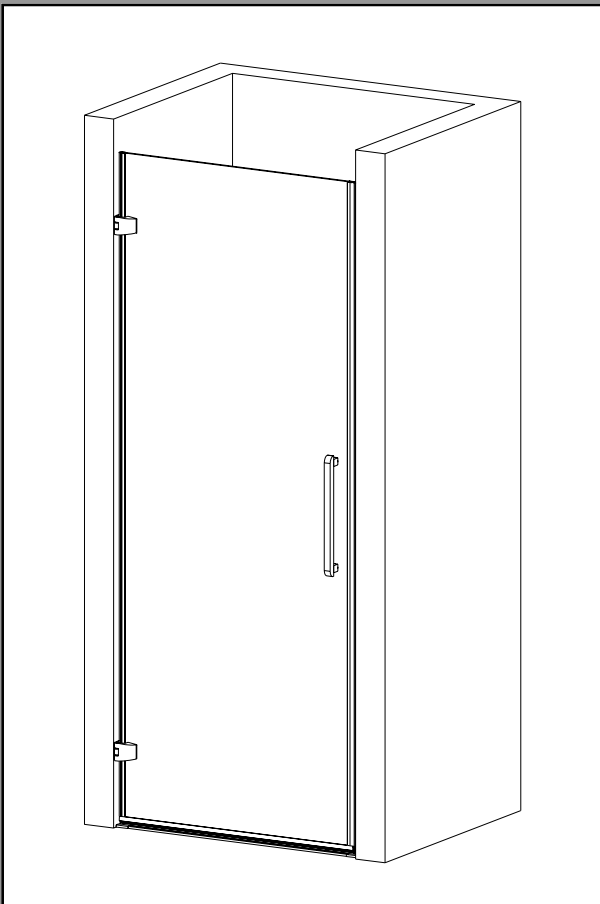

SERIE 900

APPLICAZIONE A25

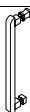

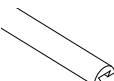
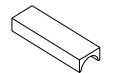
- CABINA IN NICCHIA
PORTA BATTENTE SINGOLA
- APERTURA ESTERNA 90°
- SPESSORE VETRO: 6-8mm
- ALTEZZA CABINA 1800÷2000 mm
- PESO MAX. PER COPPIA CERNIERE: 40 Kg.
- LARGHEZZA PORTA MAX 800 mm
- ACCESSORI REVERSIBILI DX/SX
- FINITURA ACCESSORI:
CROMO LUCIDO - ALTRE SU RICHIESTA -

KIT BASE cod. A25

COMPOSIZIONE KIT BASE		COD. ART.	SP. VET. mm	NR. PZ.	VARIANTI DISPON.
	CERNIERA MURO-VETRO MOD. SQUADRATO	901C	6-8	2	A / B
	MANIGLIA SINGOLA CON POMELLO INT.	C0193	6-8	1	C D
	PROFILO BATTUTA AL 10x8 H2 mt + viti di fissaggio	C0192	-	1	-
	PROFILO DI CONTENIMENTO A SILICONARE mt.1	M0212	-	1	-
	TERMINALE PER PROFILO DI CONTENIMENTO	M0210	-	2	-
	GUARNIZIONE SOTTOPORTA mt.2	AG401	6-8	1	-
	GUARNIZIONE PER CERNIERA VETRO-MURO mt.2	AG411	6-8	1	-
	GUARNIZIONE MAGNETICA PORTA mt.2	AG422 A	6-8	2	-

VARIANTI AL KIT BASE

Indicare la variante o combinazione di varianti desiderata, in sostituzione ai componenti il kit base

COD. VAR.	VARIANTI DISPONIBILI		COD. ART.	SP. VET.	NR. PZ.
A		CERNIERA MURO-VETRO MOD. SPIGOLI TONDI	901A	6-8	2
B		CERNIERA MURO-VETRO MOD. TUTTO TONDO	901B	6-8	2
C		MANIGLIA DOPPIA	C0194	6-8	1
D		COPPIA POMELLI 1 FORO VET. Ø8	C0195	6-8	1

APPLICAZIONE A25 - PREPARAZIONE LASTRE

A25

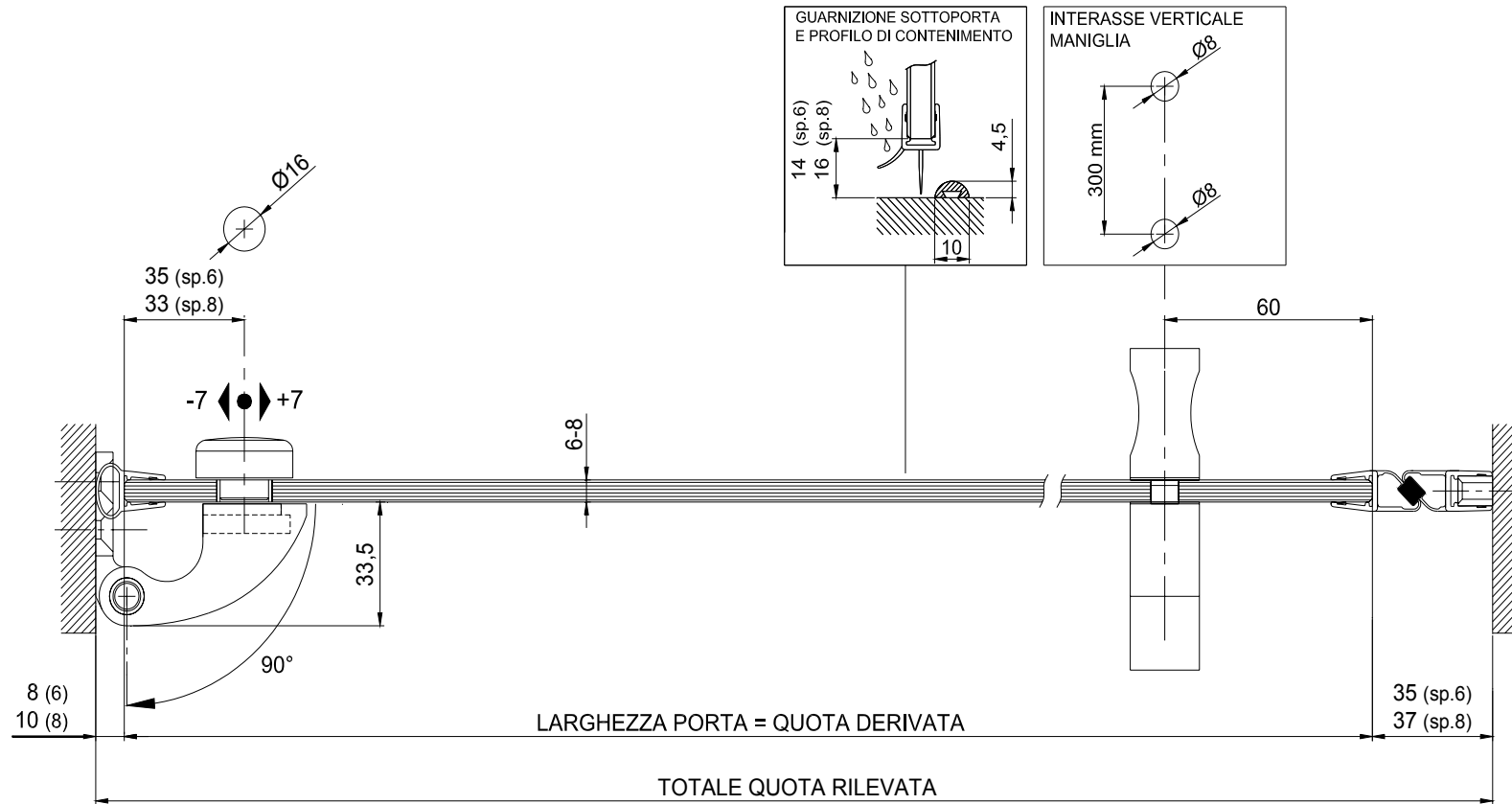



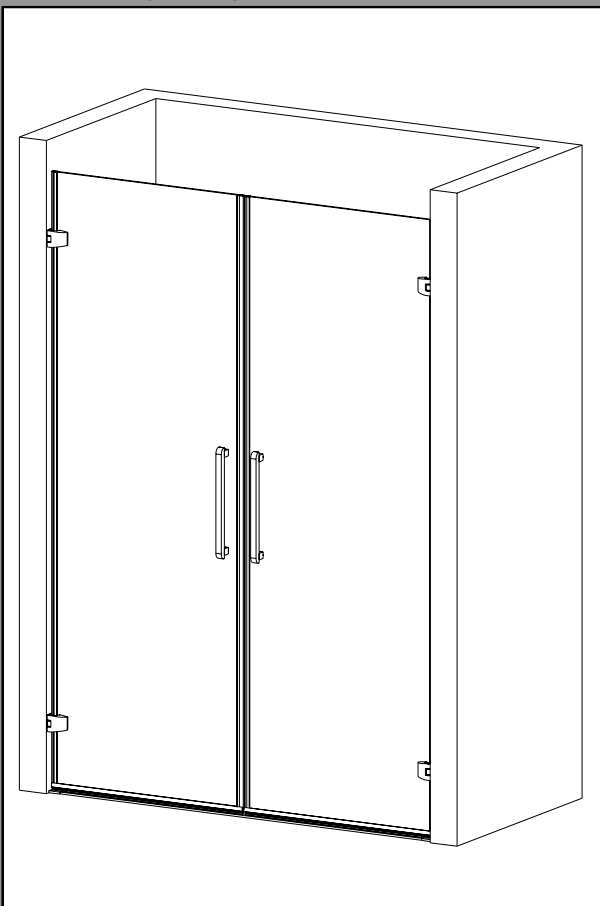

SERIE 900

APPLICAZIONE



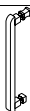
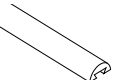

- CABINA IN NICCHIA
DOPPIA PORTA IN LINEA
- APERTURA ESTERNA 90°
- SPESSORE VETRO: 6-8mm
- ALTEZZA CABINA 1800÷2000 mm
- PESO MAX. PER COPPIA CERNIERE: 40 Kg.
- LARGHEZZA PORTA MAX 700 mm
- ACCESSORI REVERSIBILI DX/SX
- FINITURA ACCESSORI:
CROMO LUCIDO - ALTRE SU RICHIESTA -

KIT BASE cod. A26

COMPOSIZIONE KIT BASE		COD. ART.	SP. VET. mm	NR. PZ.	VARIANTI DISPON.
	CERNIERA MURO-VETRO MOD. SQUADRATO	901C	6-8	4	A / B
	MANIGLIA SINGOLA CON POMELLO INT.	C0193	6-8	2	C D
	PROFILO DI CONTENIMENTO A SILICONARE mt.1,5	M0213	-	1	-
	TERMINALE PER PROFILO DI CONTENIMENTO	M0210	-	2	-
	GUARNIZIONE SOTTOPORTA mt.2	AG401	6-8	1	-
	GUARNIZIONE PER CERNIERA VETRO-MURO mt.2	AG421	6-8	2	-
	GUARNIZIONE MAGNETICA PORTA mt.2	AG422 A	6-8	2	-

VARIANTI AL KIT BASE

Indicare la variante o combinazione di varianti desiderata, in sostituzione ai componenti il kit base

COD. VAR.	VARIANTI DISPONIBILI		COD. ART.	SP. VET.	NR. PZ.
A		CERNIERA MURO-VETRO MOD. SPIGOLI RAGG.	901A	6-8	2
B		CERNIERA MURO-VETRO MOD. TUTTO TONDO	901B	6-8	2
C		MANIGLIA DOPPIA	C0194	6-8	2
D		COPPIA POMELLI 1 FORO VET. Ø8	C0195	6-8	2

APPLICAZIONE A26 - PREPARAZIONE LASTRE

A26

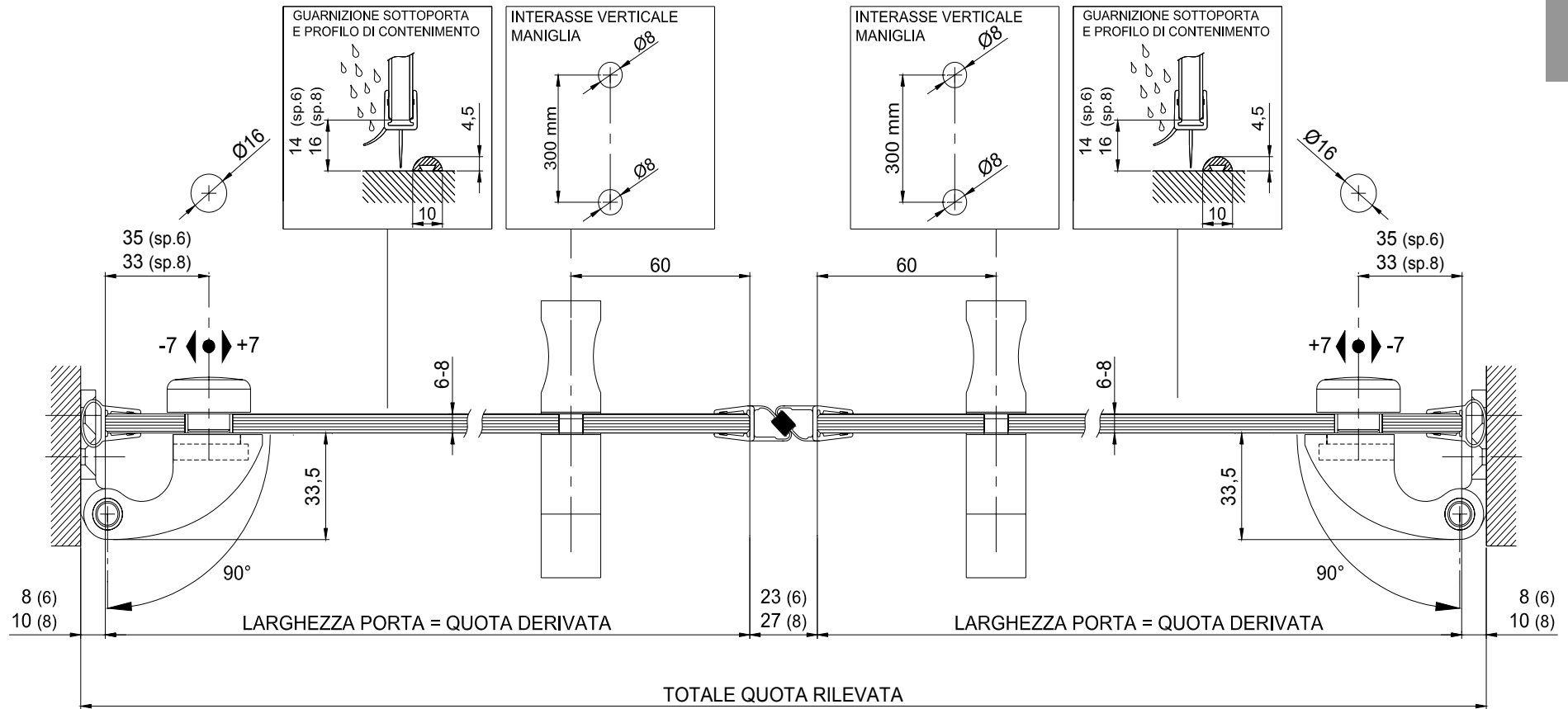





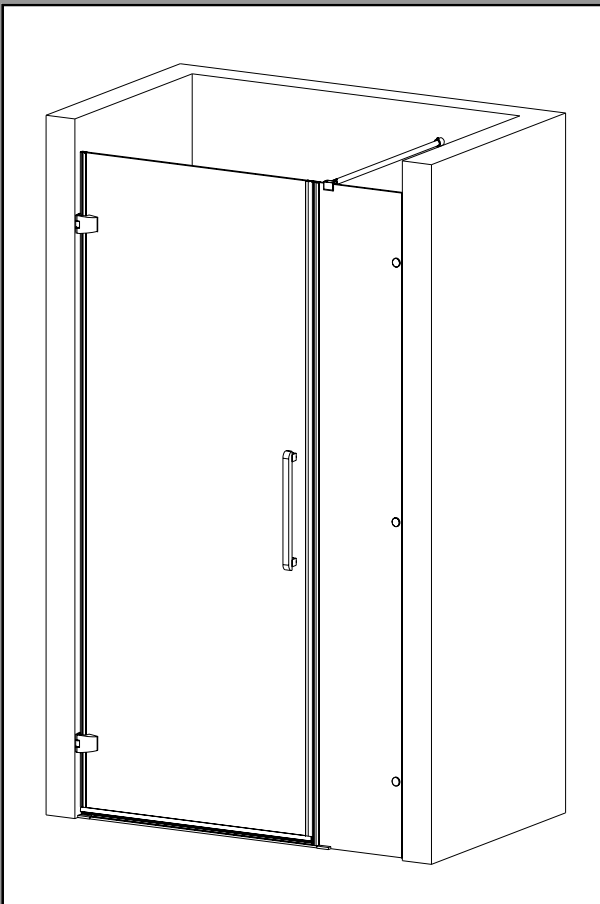



SERIE 900

APPLICAZIONE A27



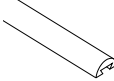
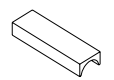
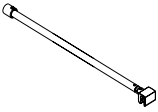







- CABINA IN NICCHIA PORTA + FISSO IN LINEA
- APERTURA ESTERNA 90°
- SPESSORE VETRO: 6-8mm
- ALTEZZA CABINA 1800÷2000 mm
- PESO MAX. PER COPPIA CERNIERE: 40 Kg.
- LARGHEZZA PORTA MAX 800 mm
- ACCESSORI REVERSIBILI DX/SX
- FINITURA ACCESSORI: CROMO LUCIDO - ALTRE SU RICHIESTA -

KIT BASE cod. A27

COMPOSIZIONE KIT BASE		COD. ART.	SP. VET. mm	NR. PZ.	VARIANTI DISPON.
	CERNIERA MURO-VETRO MOD. SQUADRATA	901C	6-8	2	A / B
	MORSETTO MURO-VETRO FISSO	C0190	6-8	3	C D
		GUARNIZIONE VETRO-MURO mt.2	AG411	6-8	
	MANIGLIA SINGOLA CON POMELLO INT.	C0193	6-8	1	E F
	PROFILO DI CONTENIMENTO A SILICONARE L= mt.1	M0212	-	1	-
	TERMINALE PER PROFILO DI CONTENIMENTO	M0210	-	2	-
	BARRA STABILIZZ. FISSA MURO-VETRO L900 mm completo viterie di fissaggio	C0168	6-8	1	G H
	GUARNIZIONE PER CERNIERA VETRO-MURO mt.2	AG411	6-8	1	-
	GUARNIZIONE SOTTOPORTA mt.2	AG401	6-8	1	-
	GUARNIZIONE MAGNETICA PORTA mt.2	AG422 A	6-8	2	-

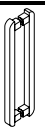
VARIANTI AL KIT BASE

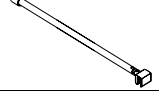
Indicare la variante o combinazione di varianti desiderata, in sostituzione ai componenti il kit base

COD. VAR.	VARIANTI DISPONIBILI		COD. ART.	SP. VET.	NR. PZ.
A		CERNIERA MURO-VETRO MOD. SPIGOLI RAGG.	901A	6-8	2
B		CERNIERA MURO-VETRO MOD. TUTTO TONDO	901B	6-8	2
C		SOLO MORSETTO MURO-VETRO FISSO	C0190	6-8	3
D		MORSETTO MURO-VETRO FISSO	C0190	6-8	3
		PROFILO "U" ALLUM. ANOD. SATIN. H mt. 2	C0196	6-8	1
E		MANIGLIA DOPPIA	C0194	6-8	1
F		COPPIA POMELLI 1 FORO VET. Ø8	C0195	6-8	1
G		BARRA STABIL. FISSA MURO-VET. L1200mm completo viterie	C0169	6-8	1
H		BARRA SNODATA 45° MURO-VET. L230mm	C0166	6-8	1
Z		GUARN. OPZIONALE VET. FISSI/BORDO PIATTO mt.2	AG110	6-8	1

APPLICAZIONE A27 - PREPARAZIONE LASTRE

A27

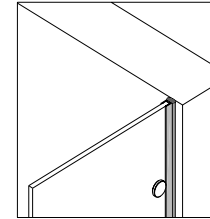
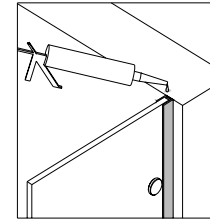
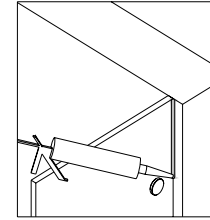
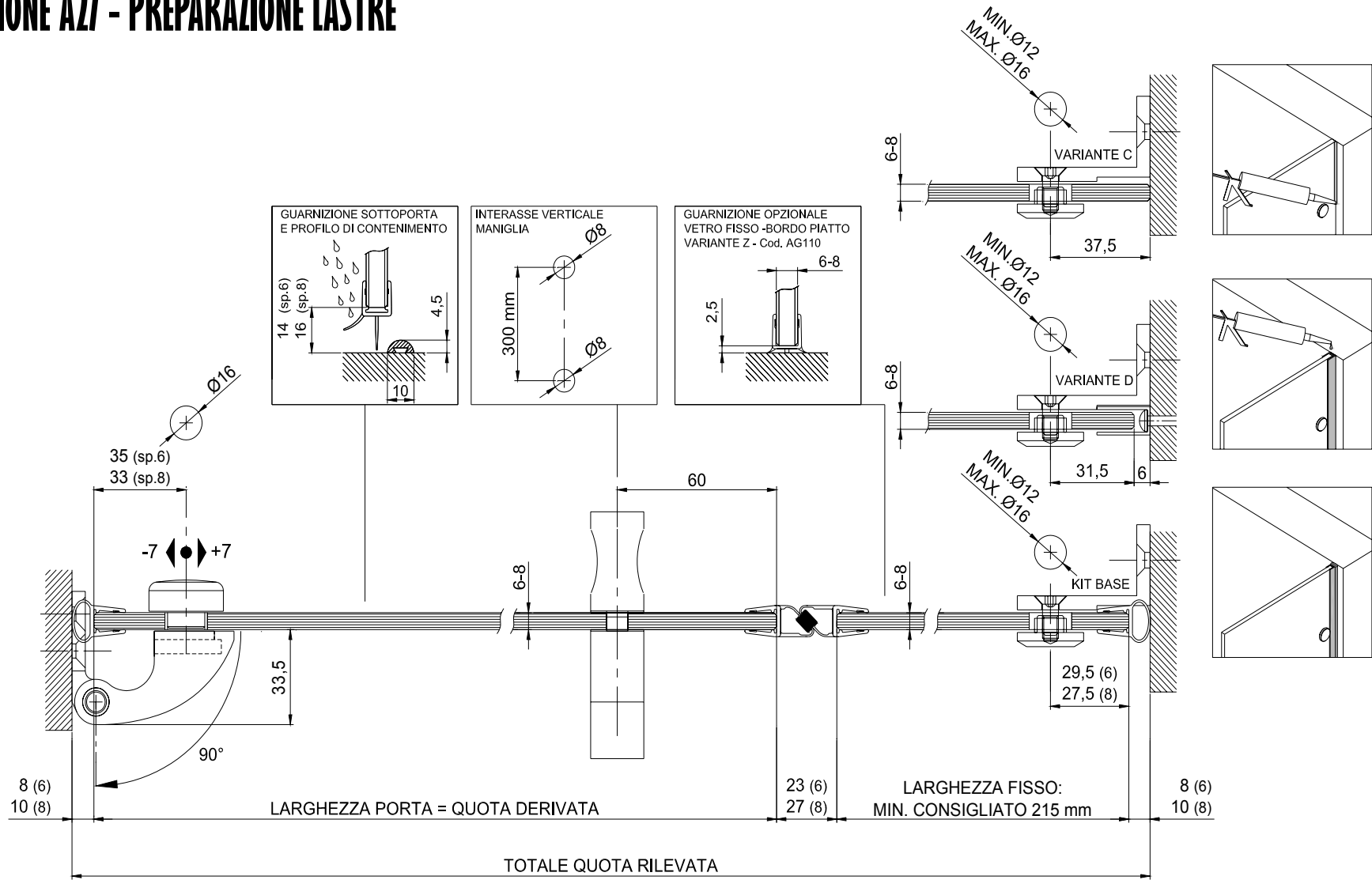

SERIE 900

APPLICAZIONE

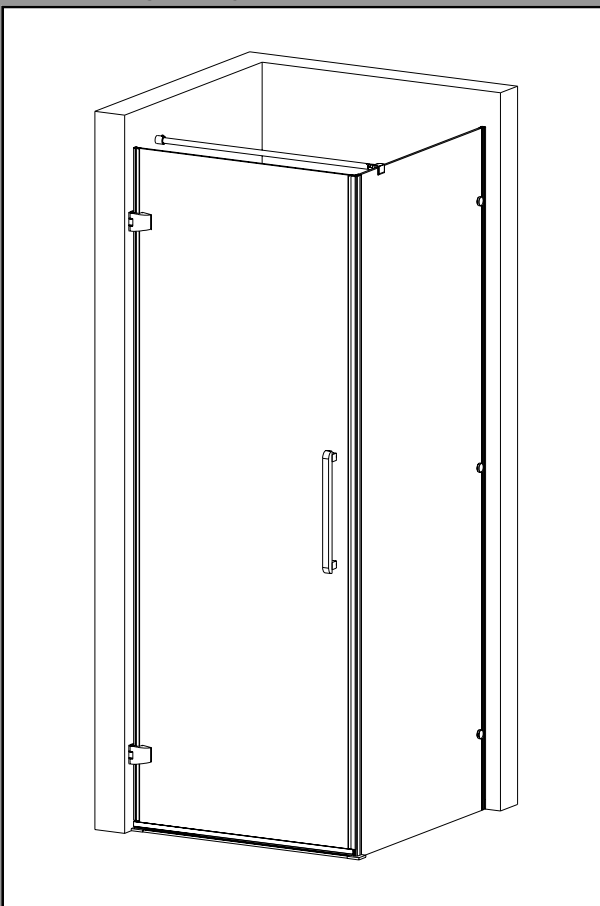

- CABINA IN ANGOLO
PORTA + FISSO LATERALE
- APERTURA ESTERNA 90°
- SPESSORE VETRO: 6-8mm
- ALTEZZA CABINA 1800+2000 mm
- PESO MAX. PER COPPIA CERNIERE: 40 Kg.
- LARGHEZZA PORTA MAX 800 mm
- ACCESSORI REVERSIBILI DX/SX
- FINITURA ACCESSORI:
CROMO LUCIDO - ALTRE SU RICHIESTA -

KIT BASE cod. A28

COMPOSIZIONE KIT BASE		COD. ART.	SP. VET. mm	NR. PZ.	VARIANTI DISPON.
	CERNIERA MURO-VETRO MOD. SQUADRATA	901C	6-8	2	A / B
	MORSETTO MURO-VETRO FISSO	C0190	6-8	3	C D
	GUARNIZIONE VETRO-MURO mt.2	AG411	6-8	1	
	MANIGLIA SINGOLA CON POMELLO INT.	C0193	6-8	1	E F
	PROFILO DI CONTENIMENTO A SILICONARE L= mt.1	M0212	-	1	-
	TERMINALE PER PROFILO DI CONTENIMENTO	M0210	-	1	-
	TERMINALE 90° PER PROFILO DI CONTENIMENTO	M0211	-	1	-
	BARRA STABILIZZ. FISSA MURO-VETRO L900 mm completo viterie	C0168	6-8	1	G H
	GUARNIZIONE PER CERNIERA VETRO-MURO mt.2	AG411	6-8	1	-
	GUARNIZIONE SOTTOPORTA mt.2	AG401	6-8	1	-
	GUARNIZIONE MAGNETICA mt.2	AG422 A	6-8	1	-
	GUARNIZIONE MAGNETICA mt.2	AG422 B	6-8	1	-

VARIANTI AL KIT BASE

Indicare la variante o combinazione di varianti desiderata, in sostituzione ai componenti il kit base

COD. VAR.	VARIANTI DISPONIBILI		COD. ART.	SP. VET. mm	NR. PZ.
A		CERNIERA MURO-VETRO MOD. SPIGOLI RAGG.	901A	6-8	2
B		CERNIERA MURO-VETRO MOD. TUTTO TONDO	901B	6-8	2
C		SOLO MORSETTO MURO-VETRO FISSO	C0190	6-8	3
D		MORSETTO MURO-VETRO FISSO	C0190	6-8	3
		PROFILO "U" ALLUM. ANOD. SATIN. H mt. 2	C0196	6-8	1
E		MANIGLIA DOPPIA	C0194	6-8	1
F		COPPIA POMELLI 1 FORO VET. Ø8	C0195	6-8	1
G		BARRA STABIL. FISSA MURO-VET. L1200mm completo viterie	C0169	6-8	1
H		BARRA SNODATA 45° MURO-VET. L230mm	C0166	6-8	1
Z		GUARN. OPZIONALE VET. FISSI/BORDO PIATTO mt.2	AG110	6-8	1

APPLICAZIONE A28 - PREPARAZIONE LASTRE

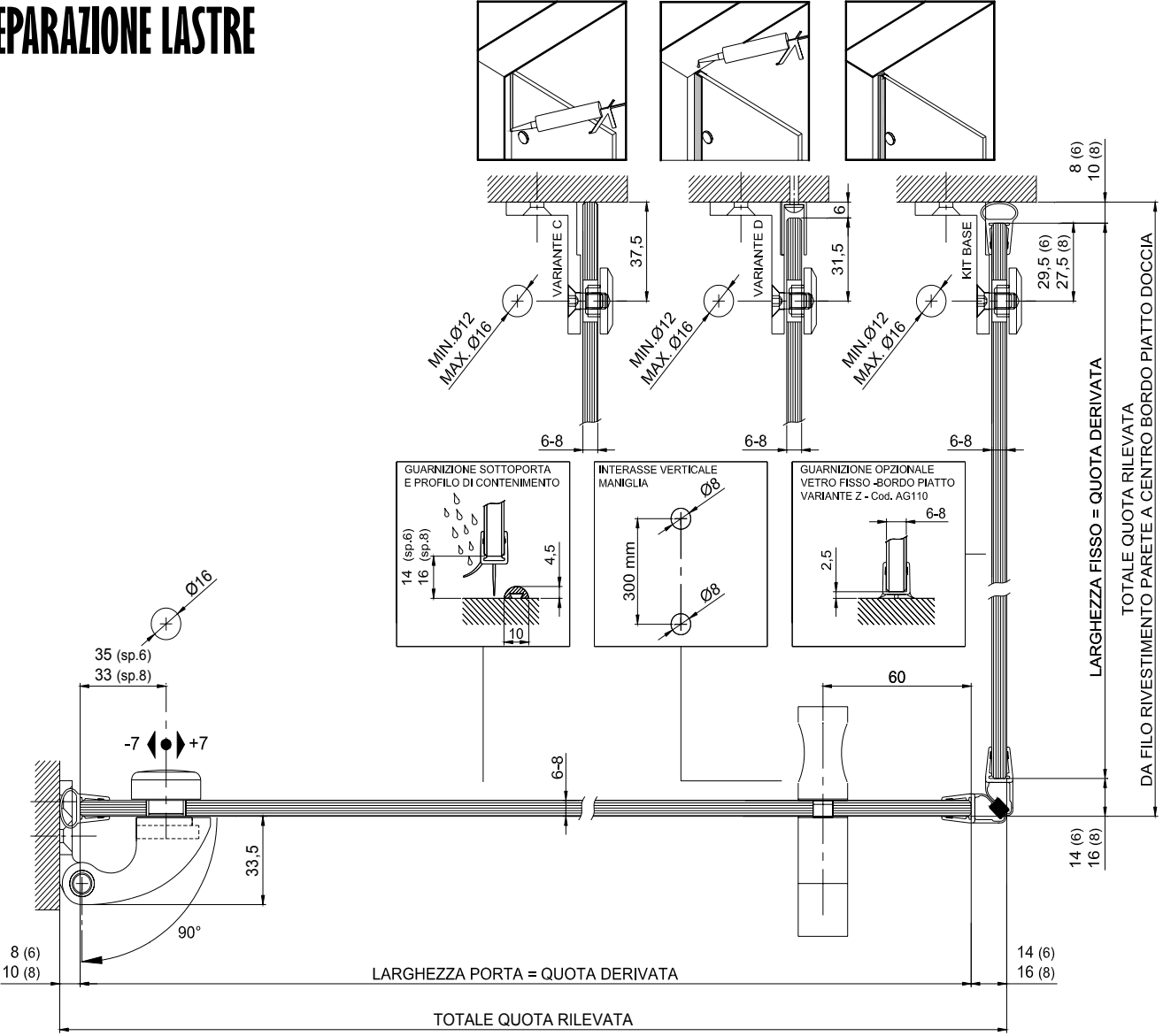





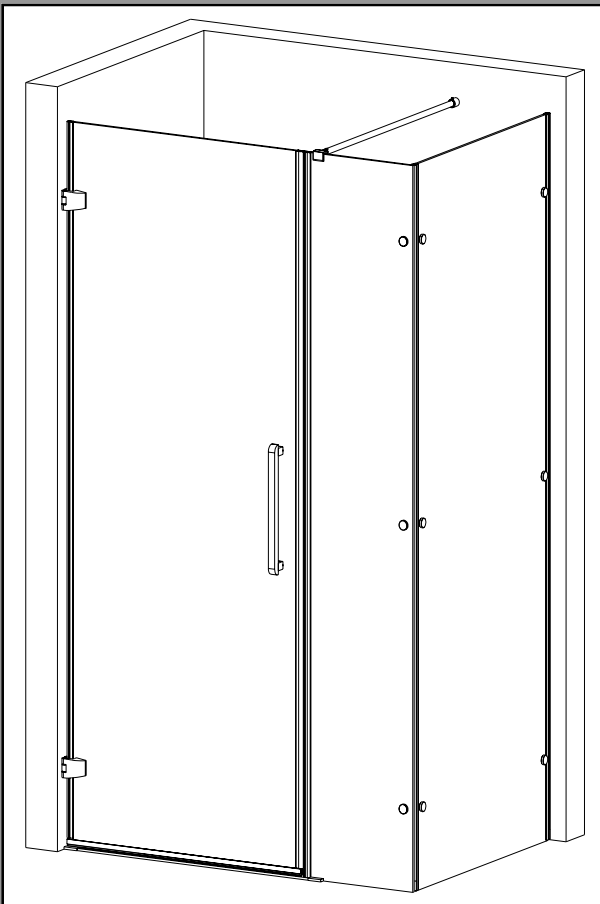







SERIE 900

APPLICAZIONE A29



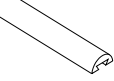
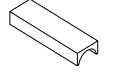
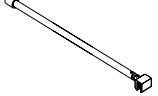







- CABINA IN ANGOLO
PORTA + FISSO IN LINEA + FISSO LATERALE
- APERTURA ESTERNA 90°
- SPESSORE VETRO: 6-8mm
- ALTEZZA CABINA 1800+2000 mm
- PESO MAX. PER COPPIA CERNIERE: 40 Kg.
- LARGHEZZA PORTA MAX 800 mm
- ACCESSORI REVERSIBILI DX/SX
- FINITURA ACCESSORI:
CROMO LUCIDO - ALTRE SU RICHIESTA -

KIT BASE cod. A29

COMPOSIZIONE KIT BASE	COD. ART.	SP. VET. mm	NR. PZ.	VARIANTI DISPON.	
 CERNIERA MURO-VETRO MOD. SQUADRATA	901C	6-8	2	A / B	
 + 	MORSETTO MURO-VETRO FISSO	C0190	6-8	3	C D
 GUARNIZIONE VETRO-MURO mt.2	AG411	6-8	1		
 + 	MORSETTO FISSO VETRO-VETRO 90°	C0191	6-8	3	E F
 GUARNIZIONE PER ANGOLO VETRO mt.2	AG411	6-8	1		
 MANIGLIA SINGOLA CON POMELLO INT.	C0193	6-8	1	G H	
 PROFILO DI CONTENIMENTO A SILICONARE L= mt.1	M0212	-	1	-	
 TERMINALE PER PROFILO DI CONTENIMENTO	M0210	-	2	-	
 BARRA STABILIZZ. FISSA MURO-VETRO L900 mm completo viterie	C0168	6-8	1	I J	
 GUARNIZIONE PER CERNIERA VETRO-MURO mt.2	AG411	6-8	1	-	
 GUARNIZIONE SOTTOPORTA mt.2	AG401	6-8	1	-	
 GUARNIZIONE MAGNETICA mt.2	AG422 A	6-8	2	-	

VARIANTI AL KIT BASE

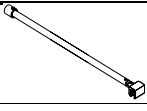
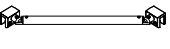
Indicare la variante o combinazione di varianti desiderata, in sostituzione ai componenti il kit base

COD. VAR.	VARIANTI DISPONIBILI	COD. ART.	SP. VET. mm	NR. PZ.	
A	 CERNIERA MURO-VETRO MOD. SPIGOLI RAGGIATI	901A	6-8	2	
B	 CERNIERA MURO-VETRO MOD. TUTTO TONDO	901B	6-8	2	
C	 SOLO MORSETTO MURO-VETRO FISSO	C0190	6-8	3	
D	 + 	MORSETTO MURO-VETRO FISSO	C0190	6-8	3
		PROFILO "U" ALLUM. ANOD. SATIN. H mt. 2	C0196	6-8	1
E	-	INCOLLAGGIO UV ANGOLO 90° (installatore)	-	-	-
F	 SOLO MORSETTO VETRO-VETRO 90°	C0191	6-8	3	
G	 MANIGLIA DOPPIA	C0194	6-8	1	
H	 COPPIA POMELLI 1 FORO VET. Ø8	C0195	6-8	1	
I	 BARRA STABIL.. FISSA MURO-VET. L1200mm completo viterie	C0169	6-8	1	
J	 BARRA SNOD. 45° VET.-VET. L230mm	C0167	6-8	1	
Z	 GUARN. OPZIONALE VET. FISSI/BORDO PIATTO mt.2	AG110	6-8	1	

APPLICAZIONE A29 - PREPARAZIONE LASTRE

A29

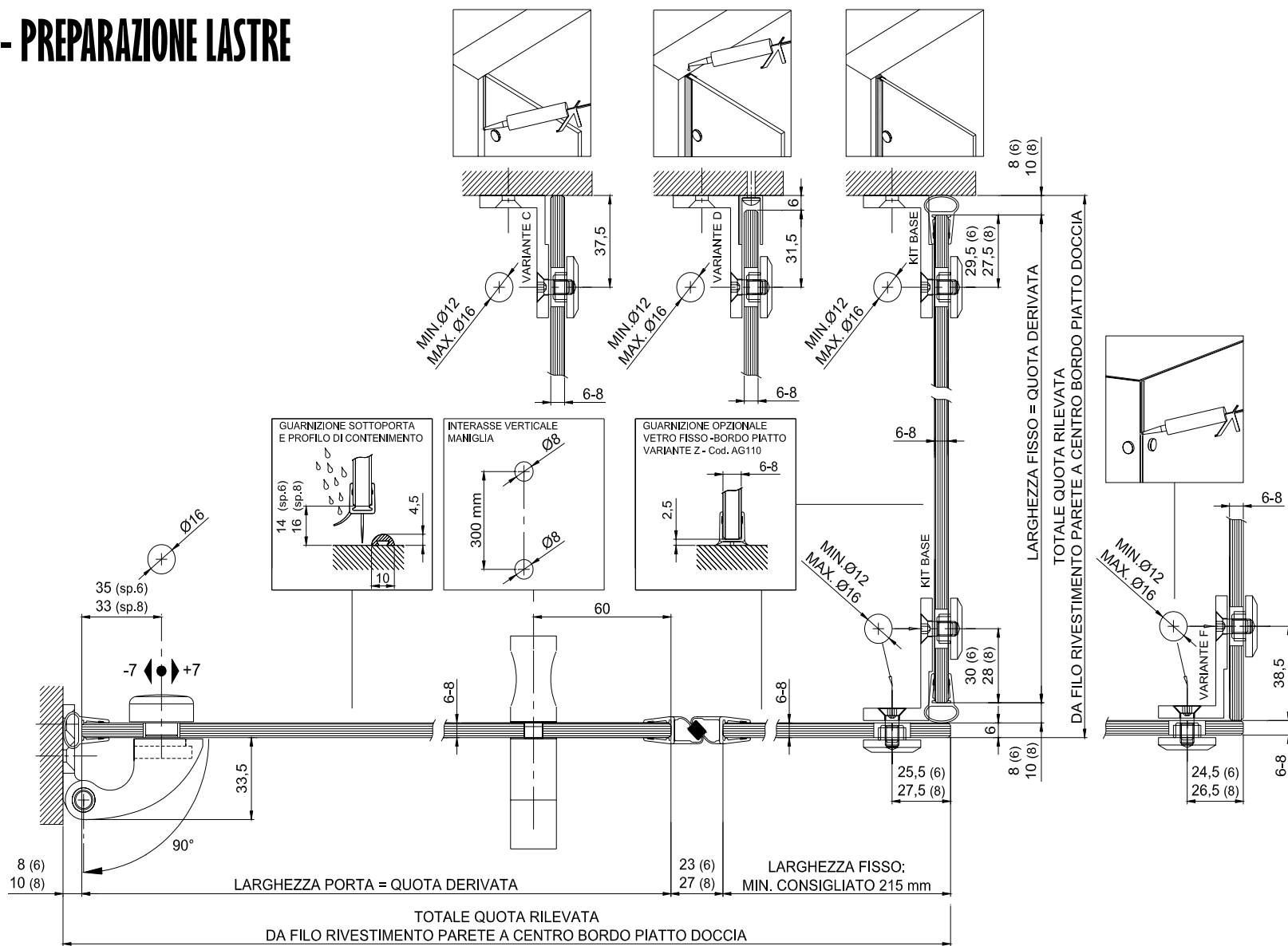





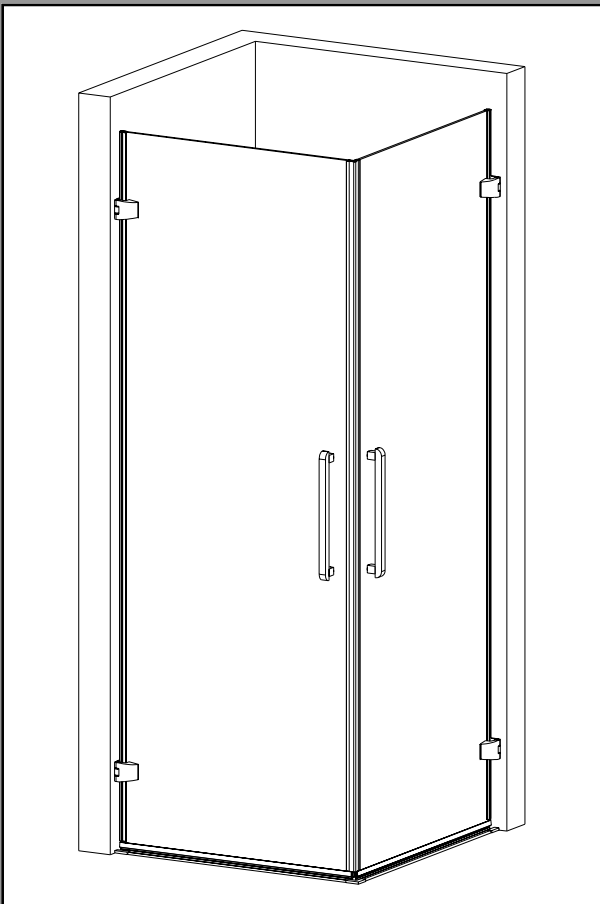

SERIE 900

APPLICAZIONE A30

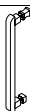
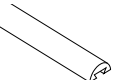

- CABINA IN ANGOLO
DOPPIA PORTA BATTENTE
- APERTURA ESTERNA 90°
- SPESSORE VETRO: 6-8mm
- ALTEZZA CABINA 1800÷2000 mm
- PESO MAX. PER COPPIA CERNIERE: 40 Kg.
- LARGHEZZA PORTA MAX 800 mm
- ACCESSORI REVERSIBILI DX/SX
- FINITURA ACCESSORI:
CROMO LUCIDO - ALTRE SU RICHIESTA -

KIT BASE cod. A30

COMPOSIZIONE KIT BASE		COD. ART.	SP. VET. mm	NR. PZ.	VARIANTI DISPON.
	CERNIERA MURO-VETRO MOD. SQUADRATO	901C	6-8	4	A / B
	MANIGLIA SINGOLA CON POMELLO INT.	C0193	6-8	2	C D
	PROFILO DI CONTENIMENTO A SILICONARE mt.1	M0212	-	2	-
	TERMINALE PER PROFILO DI CONTENIMENTO	M0210	-	2	-
	TERMINALE 90° PER PROFILO DI CONTENIMENTO	M0211	-	1	-
	GUARNIZIONE SOTTOPORTA mt.2	AG40 1	6-8	1	-
	GUARNIZIONE PER CERNIERA VETRO-MURO mt.2	AG41 1	6-8	2	-
	GUARNIZIONE MAGNETICA PORTA mt.2	AG42 2A	6-8	1	-
	GUARNIZIONE MAGNETICA LATO FISSO mt.2	AG42 2B	6-8	1	-

VARIANTI AL KIT BASE

Indicare la variante o combinazione di varianti desiderata, in sostituzione ai componenti il kit base

COD. VAR.	VARIANTI DISPONIBILI		COD. ART.	SP. VET. mm	NR. PZ.
A		CERNIERA MURO-VETRO MOD. SPIGOLI RAGG.	901A	6-8	2
B		CERNIERA MURO-VETRO MOD. TUTTO TONDO	901B	6-8	2
C		MANIGLIA DOPPIA	C0194	6-8	2
D		COPPIA POMELLI 1 FORO VET. Ø8	C0195	6-8	2

APPLICAZIONE A30 - PREPARAZIONE LASTRE

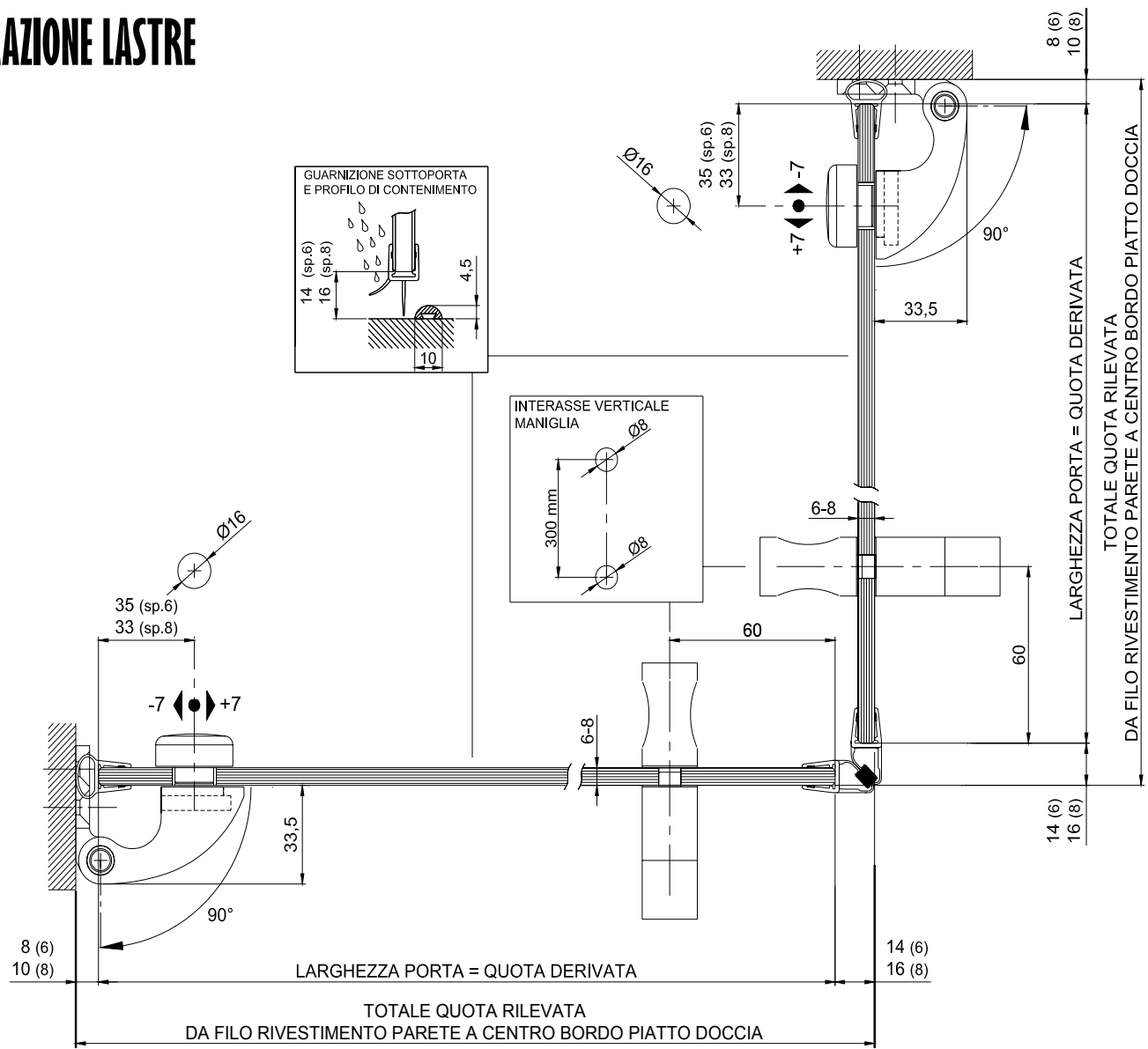



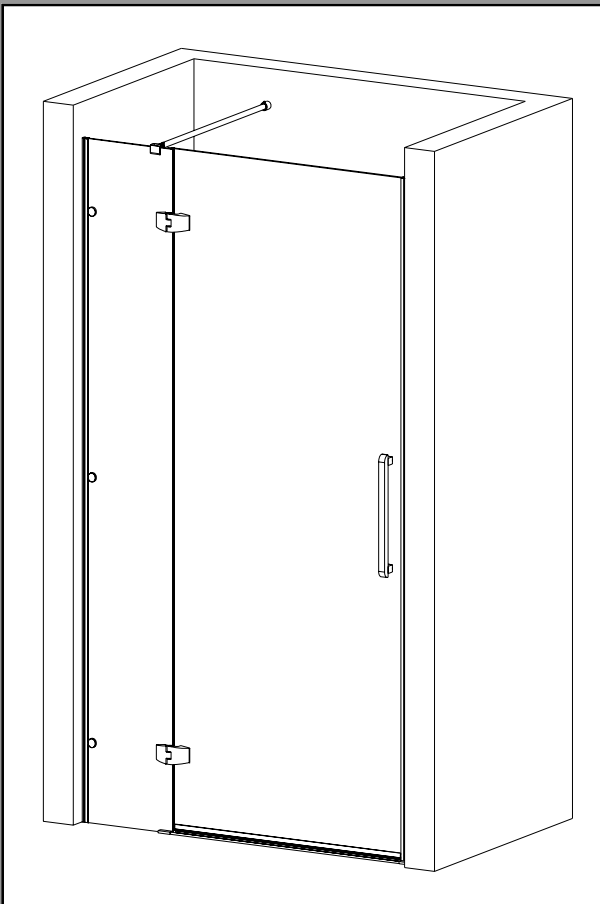







APPLICAZIONE A31

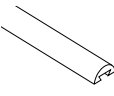

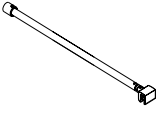







- CABINA IN ANGOLO
DOPPIA PORTA BATTENTE
- APERTURA ESTERNA 90°
- SPESSORE VETRO: 6 mm
- ALTEZZA CABINA 1800+2000 mm
- PESO MAX. PER COPPIA CERNIERE: 40 Kg.
- LARGHEZZA PORTA MAX 800 mm
- ACCESSORI REVERSIBILI DX/SX
- FINITURA ACCESSORI:
CROMO LUCIDO - ALTRE SU RICHIESTA -

KIT BASE cod. A31

COMPOSIZIONE KIT BASE		COD. ART.	SP. VET. mm	NR. PZ.	VARIANTI DISPON.
	CERNIERA VETRO-VETRO MOD. SQUADRATA	900C	6	2	A / B
	MORSETTO MURO-VETRO FISSO	C0190	6-8	3	C D E
		GUARNIZIONE VETRO-MURO mt.2	AG411	6-8	
	MANIGLIA SINGOLA CON POMELLO INT.	C0193	6-8	1	F G
	PROFILO BATTUTA AL H mt. 2 completo viterie fissaggio	C0192	-	1	-
	PROFILO DI CONTENIMENTO A SILICONARE L= mt.1	M0212	-	1	-
	TERMINALE PER PROFILO DI CONTENIMENTO	M0210	-	2	-
	BARRA STABILIZZ. FISSA MURO-VETRO L900 mm completo viterie	C0168	6-8	1	H I
	GUARNIZIONE SOTTOPORTA mt.2	AG401	6-8	1	-
	GUARNIZIONE PER CERNIERA VETRO-VETRO mt.2	AG140	6-8	1	-
	GUARNIZIONE MAGNETICA mt.2	AG422 A	6-8	2	-

VARIANTI AL KIT BASE

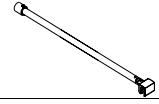
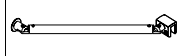
Indicare la variante o combinazione di varianti desiderata, in sostituzione ai componenti il kit base

COD. VAR.	VARIANTI DISPONIBILI		COD. ART.	SP. VET. mm	NR. PZ.
A		CERNIERA VETRO-VETRO MOD. SPIGOLI RAGG.	900A	6	2
B		CERNIERA VETRO-VETRO MOD. TUTTO TONDO	900B	6	2
C		SOLO MORSETTO FISSO MURO-VETRO	C0190	6-8	3
D		MORSETTO MURO-VETRO FISSO	C0190	6-8	3
		PROFILO "U" ALLUM. ANOD. SATIN. H mt. 2	C0196	6-8	1
F		MANIGLIA DOPPIA	C0194	6-8	1
G		COPPIA POMELLI 1 FORO VET. Ø8	C0195	6-8	1
H		BARRA STABIL. FISSA MURO-VET. L1200mm completo viterie	C0169	6-8	1
I		BARRA SNODATA 45° MURO-VET. L230mm	C0166	6-8	1
Z		GUARN. OPZIONALE VET. FISSI/BORDO PIATTO mt.2	AG110	6-8	1

APPLICAZIONE A31 - PREPARAZIONE LASTRE

A31

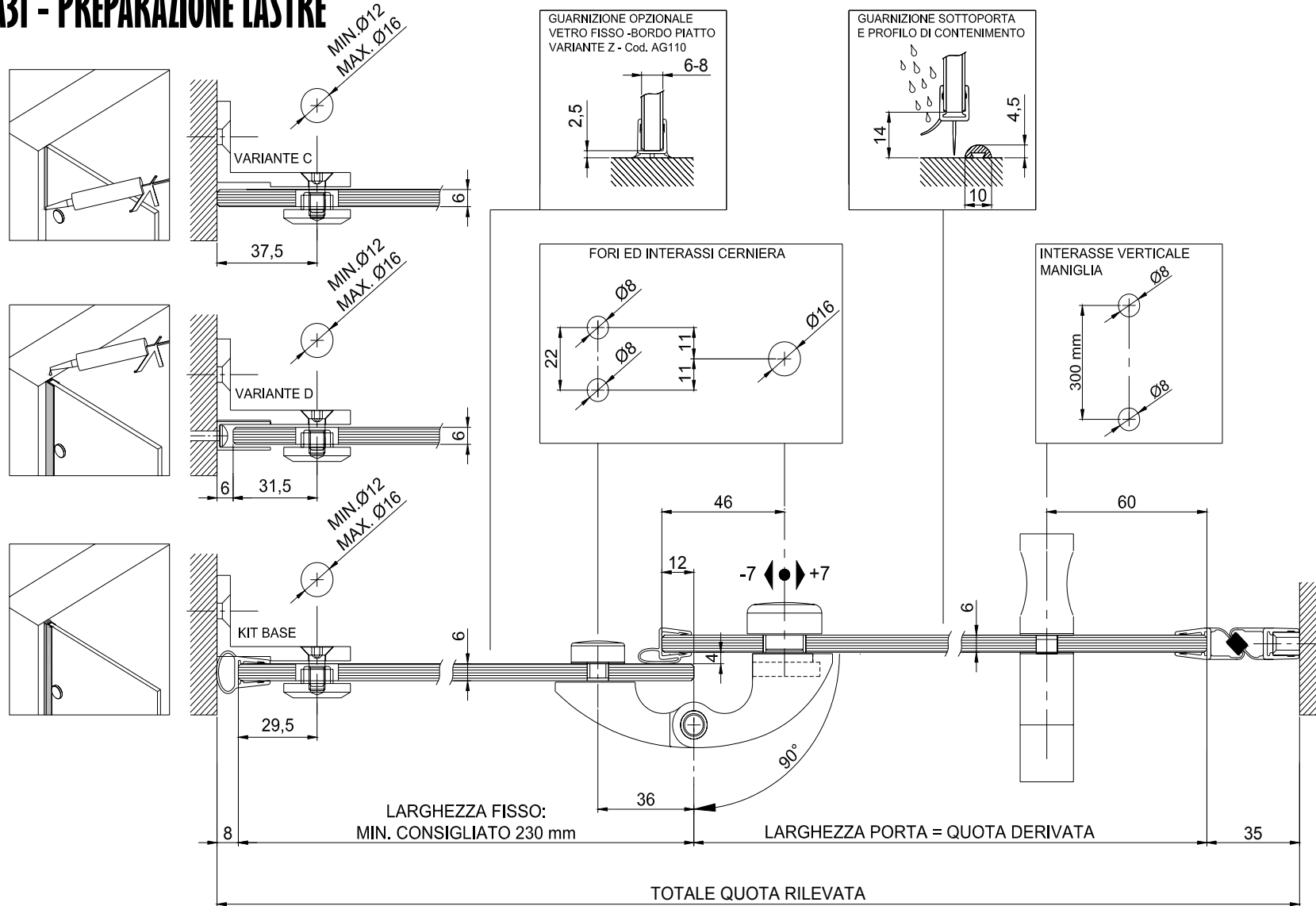





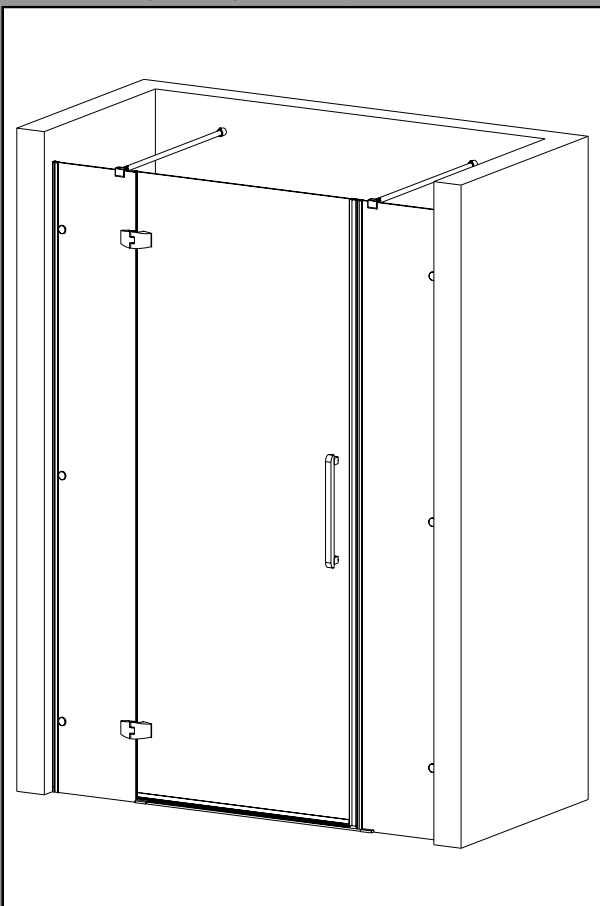



SERIE 900

APPLICAZIONE A32



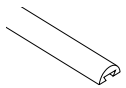

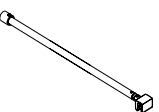
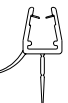





- CABINA IN NICCHIA FISSO + PORTA IN LINEA + FISSO
- APERTURA ESTERNA 90°
- SPESSORE VETRO: 6 mm
- ALTEZZA CABINA 1800÷2000 mm
- PESO MAX. PER COPPIA CERNIERE: 40 Kg.
- LARGHEZZA PORTA MAX 800 mm
- ACCESSORI REVERSIBILI DX/SX
- FINITURA ACCESSORI: CROMO LUCIDO - ALTRE SU RICHIESTA -

KIT BASE cod. A32

COMPOSIZIONE KIT BASE		COD. ART.	SP. VET. mm	NR. PZ.	VARIANTI DISPON.
	CERNIERA VETRO-VETRO MOD. SQUADRATA	900C	6	2	A / B
	MORSETTO MURO-VETRO FISSO	C0190	6-8	6	C D
					
	MANIGLIA SINGOLA CON POMELLO INT.	C0193	6-8	1	E F
	PROFILO DI CONTENIMENTO A SILICONARE L= mt.1	M0212	-	1	-
	TERMINALE PER PROFILO DI CONTENIMENTO	M0210	-	2	-
	BARRA STABILIZZ. FISSA MURO-VETRO L900 mm completo viterie	C0168	6-8	2	G H
	GUARNIZIONE SOTTOPORTA mt.2	AG401	6-8	1	-
	GUARNIZIONE PER CERNIERA VETRO-VETRO mt.2	AG140	6-8	1	-
	GUARNIZIONE MAGNETICA mt.2	AG422 A	6-8	2	-

VARIANTI AL KIT BASE

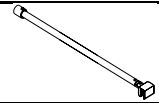
Indicare la variante o combinazione di varianti desiderata, in sostituzione ai componenti il kit base

COD. VAR.	VARIANTI DISPONIBILI		COD. ART.	SP. VET. mm	NR. PZ.
A		CERNIERA VETRO-VETRO MOD. SPIGOLI RAGG.	900A	6	2
B		CERNIERA VETRO-VETRO MOD. TUTTO TONDO	900B	6	2
C		SOLO MORSETTO FISSO MURO-VETRO	C0190	6-8	6
D		MORSETTO MURO-VETRO FISSO	C0190	6-8	6
		PROFILO "U" ALLUM. ANOD. SATIN. H mt. 2	C0196	6-8	2
E		MANIGLIA DOPPIA	C0194	6-8	1
F		COPPIA POMELLI 1 FORO VET. Ø8	C0195	6-8	1
G		BARRA STABIL. FISSA MURO-VET. L1200mm completo viterie	C0169	6-8	2
H		BARRA SNODATA 45° MURO-VET. L230mm	C0166	6-8	2
Z		GUARN. OPZIONALE VET. FISSI/BORDO PIATTO mt.2	AG110	6-8	1

APPLICAZIONE A32 - PREPARAZIONE LASTRE

A32

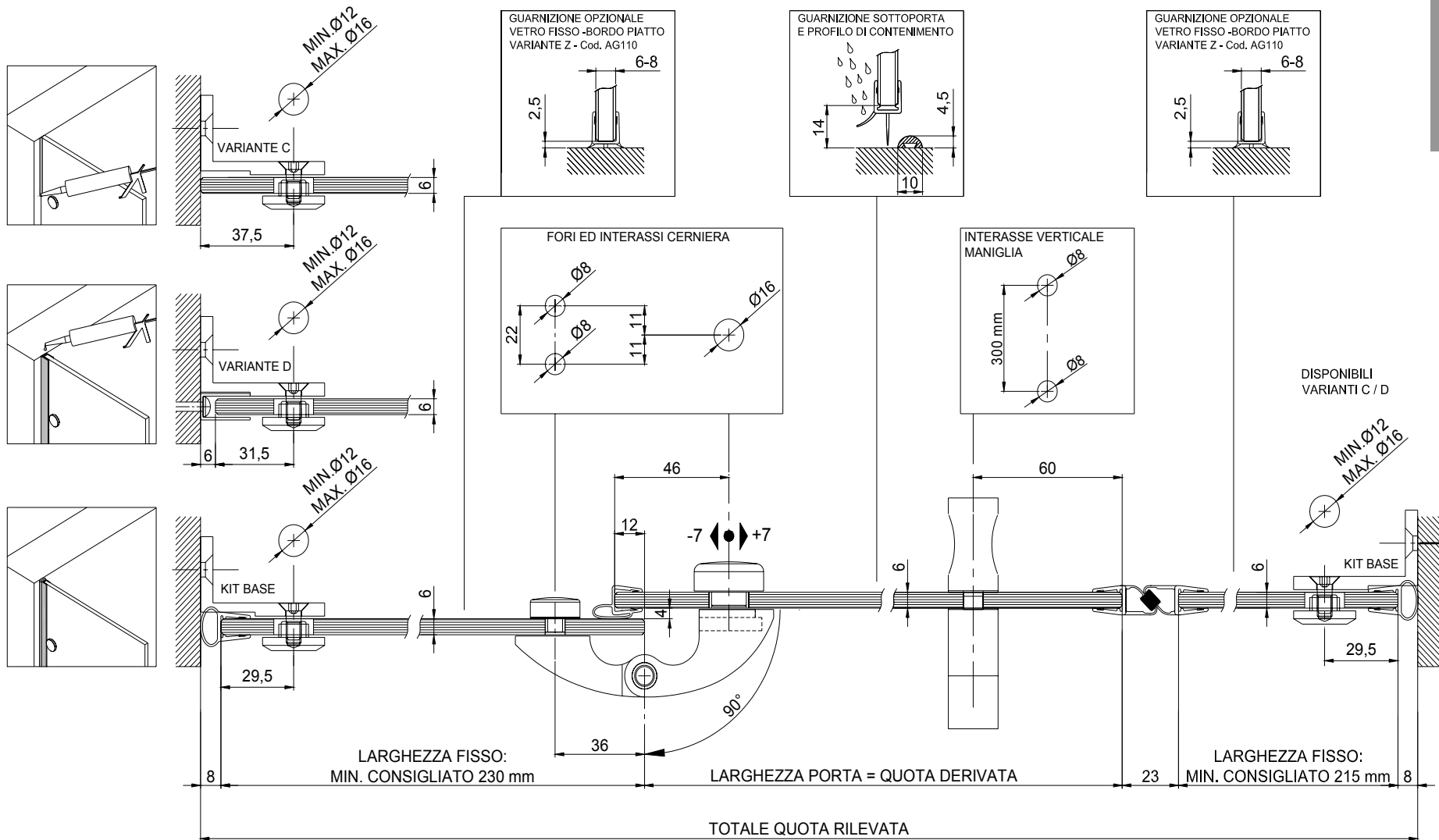





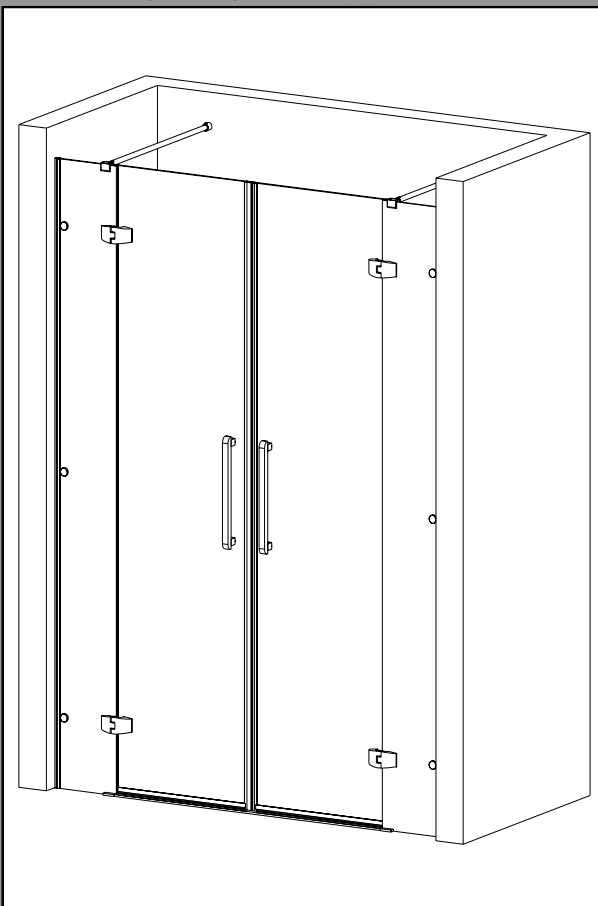



SERIE 900

APPLICAZIONE A33



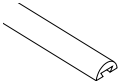

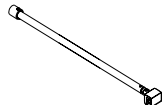
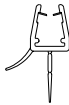





- CABINA IN NICCHIA
2 FISSI + DOPPIA PORTA IN LINEA
- APERTURA ESTERNA 90°
- SPESSORE VETRO: 6 mm
- ALTEZZA CABINA 1800+2000 mm
- PESO MAX. PER COPPIA CERNIERE: 40 Kg.
- LARGHEZZA PORTA MAX 700 mm
- ACCESSORI REVERSIBILI DX/SX
- FINITURA ACCESSORI:
CROMO LUCIDO - ALTRE SU RICHIESTA -

KIT BASE cod. A33

COMPOSIZIONE KIT BASE		COD. ART.	SP. VET. mm	NR. PZ.	VARIANTI DISPON.
	CERNIERA VETRO-VETRO MOD. SQUADRATA	900C	6-8	4	A / B
	MORSETTO MURO-VETRO FISSO	C0190	6-8	6	C D
		AG411	6-8	2	
	MANIGLIA SINGOLA CON POMELLO INT.	C0193	6-8	2	E F
	PROFILO DI CONTENIMENTO A SILICONARE L= mt.1,5	M0213	-	1	-
	TERMINALE PER PROFILO DI CONTENIMENTO	M0210	-	2	-
	BARRA STABILIZZ. FISSA MURO-VETRO L900 mm completo viterie	C0168	6-8	2	G H
	GUARNIZIONE SOTTOPORTA mt.2	AG401	6-8	1	-
	GUARNIZIONE PER CERNIERA VETRO-VETRO mt.2	AG140	6-8	2	-
	GUARNIZIONE MAGNETICA mt.2	AG422 A	6-8	2	-

VARIANTI AL KIT BASE

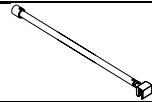
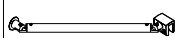
Indicare la variante o combinazione di varianti desiderata, in sostituzione ai componenti il kit base

COD. VAR.	VARIANTI DISPONIBILI		COD. ART.	SP. VET. mm	NR. PZ.
A		CERNIERA VETRO-VETRO MOD. SPIGOLI RAGG.	900A	6-8	4
B		CERNIERA VETRO-VETRO MOD. TUTTO TONDO	900B	6-8	4
C		SOLO MORSETTO FISSO MURO-VETRO	C0190	6-8	6
D		MORSETTO MURO-VETRO FISSO	C0190	6-8	6
		PROFILO "U" ALLUM. ANOD. SATIN. H mt. 2	C0196	6-8	2
E		MANIGLIA DOPPIA	C0194	6-8	2
F		COPPIA POMELLI 1 FORO VET. Ø8	C0195	6-8	2
G		BARRA STABIL. FISSA MURO-VET. L1200mm completo viterie	C0169	6-8	2
H		BARRA SNODATA 45° MURO-VET. L230mm	C0166	6-8	2
Z		GUARN. OPZIONALE VET. FISSI/BORDO PIATTO mt.2	AG110	6-8	1

APPLICAZIONE A33 - PREPARAZIONE LASTRE

A33

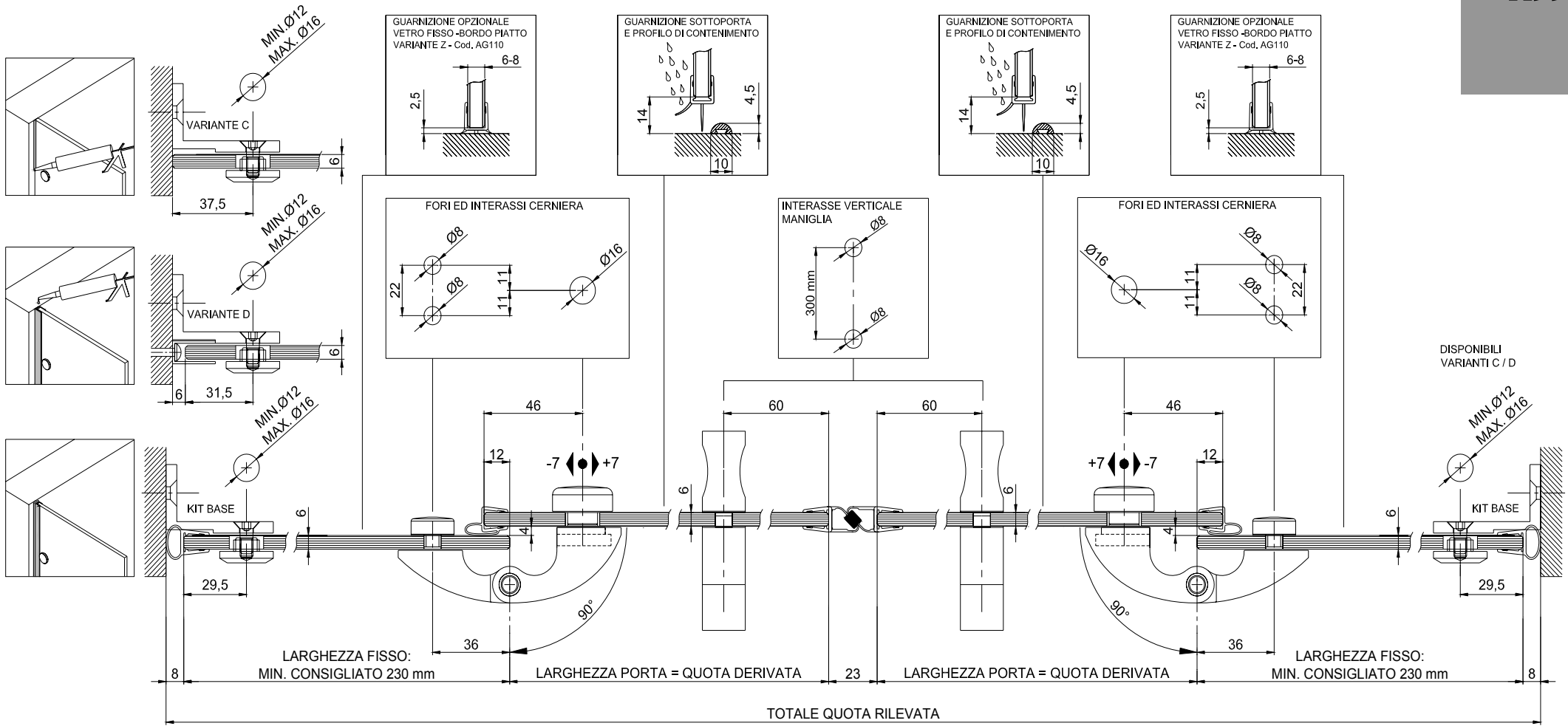

SERIE 900

APPLICAZIONE A34

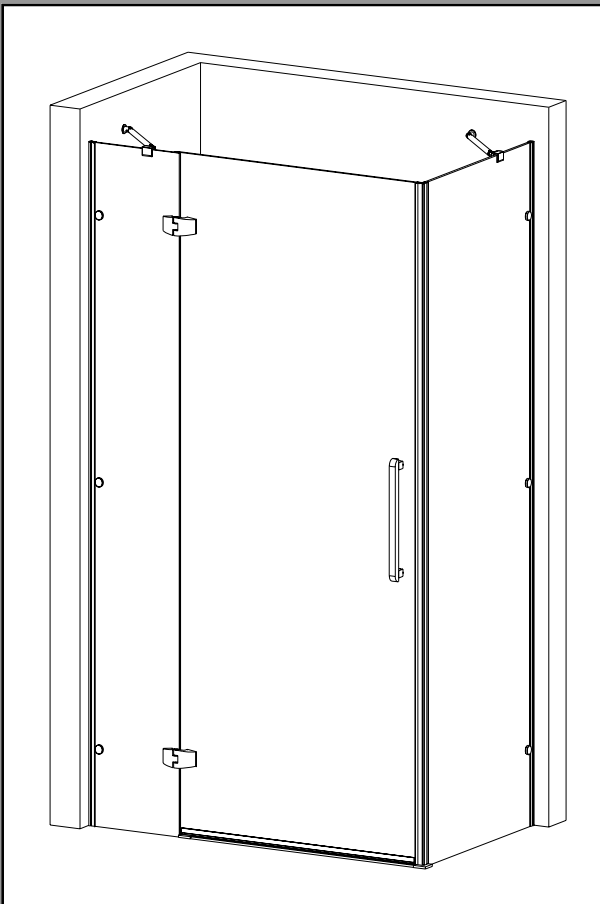









- CABINA IN ANGOLO FISSO + PORTA IN LINEA + FISSO LATERALE
- APERTURA ESTERNA 90°
- SPESSORE VETRO: 6 mm
- ALTEZZA CABINA 1800+2000 mm
- PESO MAX. PER COPPIA CERNIERE: 40 Kg.
- LARGHEZZA PORTA MAX 800 mm
- ACCESSORI REVERSIBILI DX/SX
- FINITURA ACCESSORI: CROMO LUCIDO - ALTRE SU RICHIESTA -

KIT BASE cod. A34

COMPOSIZIONE KIT BASE	COD. ART.	SP. VET. mm	NR. PZ.	VARIANTI DISPON.
 CERNIERA VETRO-VETRO MOD. SQUADRATA	900C	6	2	A / B
 +  MORSETTO MURO-VETRO FISSO	C0190	6-8	6	C D
 GUARNIZIONE VETRO-MURO mt.2	AG411	6-8	2	
 MANIGLIA SINGOLA CON POMELLO INT.	C0193	6-8	1	E F
 PROFILO DI CONTENIMENTO A SILICONARE L= mt.1	M0212	-	1	-
 TERMINALE PER PROFILO DI CONTENIMENTO	M0210	-	1	-
 TERMINALE 90° PER PROFILO DI CONTENIMENTO	M0211	-	1	-
 BARRA SNODATA 45° MURO-VET. L230mm	C0166	6-8	2	-
 GUARNIZIONE SOTTOPORTA mt.2	AG401	6-8	1	-
 GUARNIZIONE PER CERNIERA VETRO-VETRO mt.2	AG140	6-8	2	-
 GUARNIZIONE MAGNETICA mt.2	AG422 A	6-8	1	-
 GUARNIZIONE MAGNETICA mt.2	AG422 B	6-8	1	-

VARIANTI AL KIT BASE

Indicare la variante o combinazione di varianti desiderata, in sostituzione ai componenti il kit base

COD. VAR.	VARIANTI DISPONIBILI	COD. ART.	SP. VET. mm	NR. PZ.
A	 CERNIERA VETRO-VETRO MOD. SPIGOLI RAGG.	900A	6	2
B	 CERNIERA VETRO-VETRO MOD. TUTTO TONDO	900B	6	2
C	 SOLO MORSETTO FISSO MURO-VETRO	C0190	6-8	6
D	 MORSETTO MURO-VETRO FISSO	C0190	6-8	6
	+  PROFILO "U" ALLUM. ANOD. SATIN. H mt. 2	C0196	6-8	2
E	 MANIGLIA DOPPIA	C0194	6-8	1
F	 COPPIA POMELLI 1 FORO VET. Ø8	C0195	6-8	1
Z	 GUARN. OPZIONALE VET. FISSI/BORDO PIATTO mt.2	AG110	6-8	1

APPLICAZIONE A34 - PREPARAZIONE LASTRE

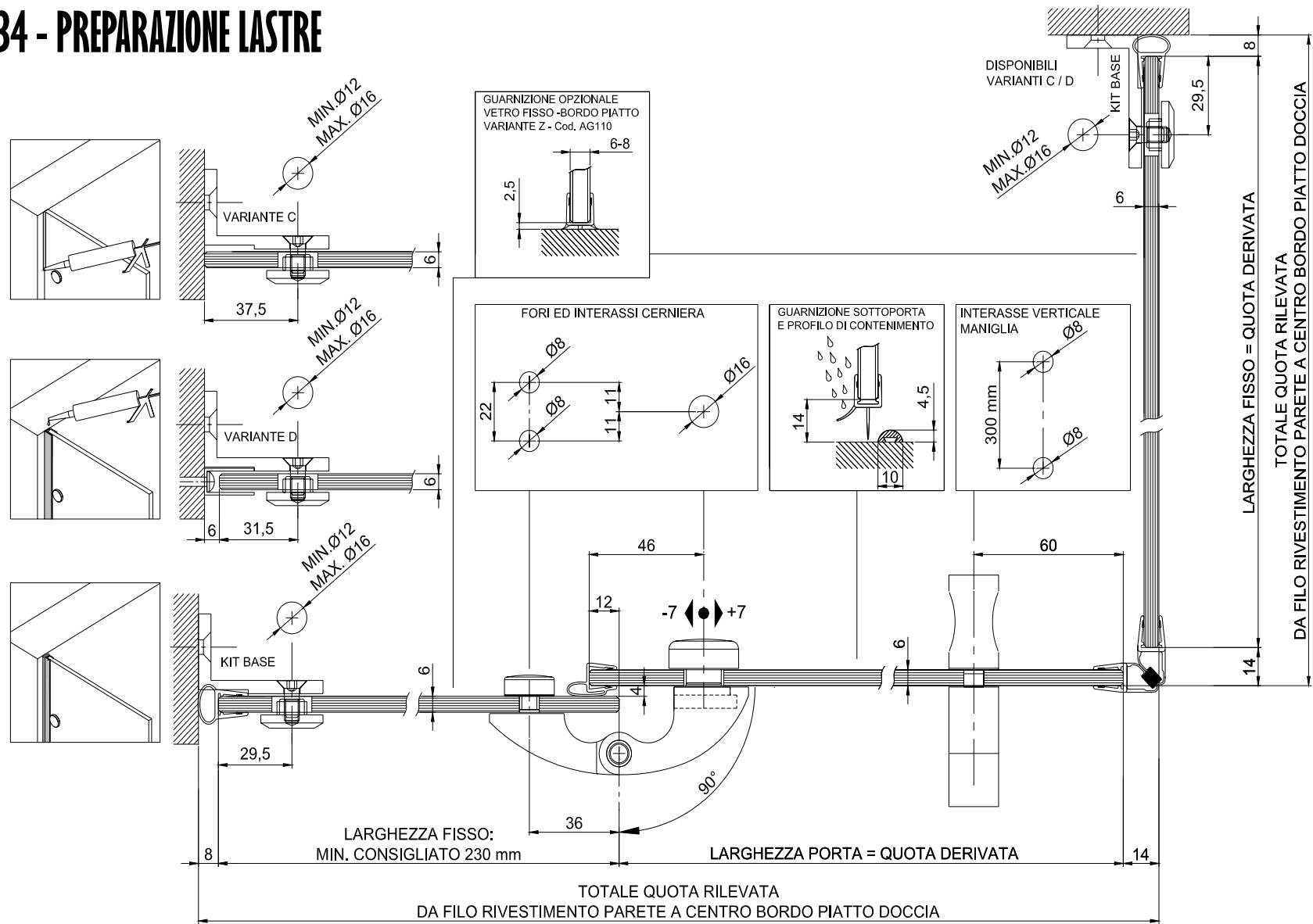

A34





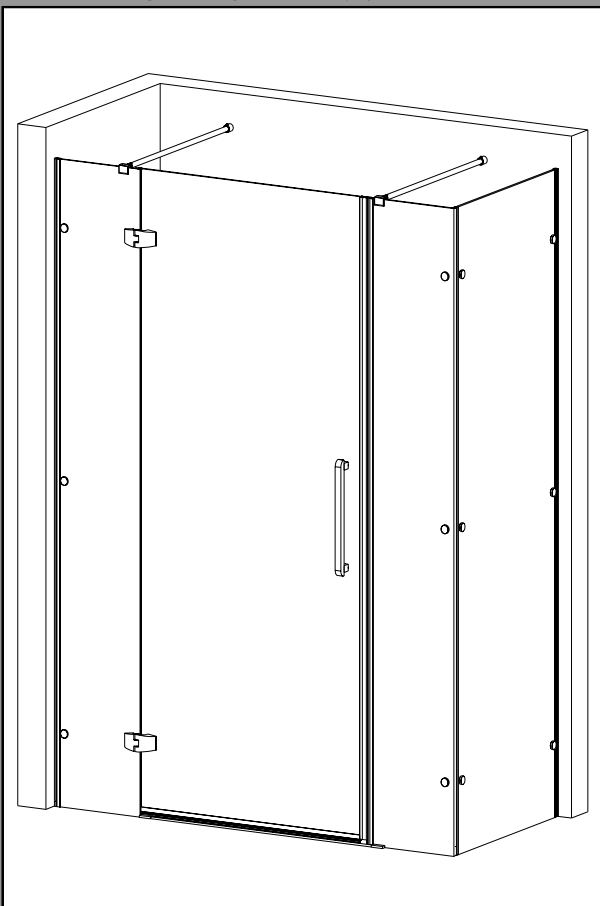









SERIE 900

APPLICAZIONE A35

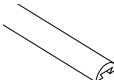

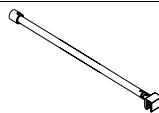













- CABINA IN ANGOLO FISSO+PORTA+FISSO IN LINEA + FISSO LAT.
- APERTURA ESTERNA 90°
- SPESSORE VETRO: 6 mm
- ALTEZZA CABINA 1800÷2000 mm
- PESO MAX. PER COPPIA CERNIERE: 40 Kg.
- LARGHEZZA PORTA MAX 800 mm
- ACCESSORI REVERSIBILI DX/SX
- FINITURA ACCESSORI: CROMO LUCIDO - ALTRE SU RICHIESTA -

KIT BASE cod. A35

COMPOSIZIONE KIT BASE	COD. ART.	SP. VET. mm	NR. PZ.	VARIANTI DISPON.
 CERNIERA VETRO-VETRO MOD. SQUADRATA	900C	6	2	A / B
 +  MORSETTO MURO-VETRO FISSO	C0190	6-8	3	C D
 GUARNIZIONE VETRO-MURO mt.2	AG411	6-8	1	
 +  MORSETTO FISSO VETRO-VETRO 90°	C0190	6-8	3	E F
 GUARNIZIONE PER ANGOLO VETRO mt.2	AG411	6-8	1	
 MANIGLIA SINGOLA CON POMELLO INT.	C0193	6-8	1	G H
 PROFILO DI CONTENIMENTO A SILICONARE L= mt.1	M0212	-	1	-
 TERMINALE PER PROFILO DI CONTENIMENTO	M0210	-	2	-
 BARRA STABILIZZ. FISSA MURO-VETRO L900 mm completo viterie	C0168	6-8	1	I J
 GUARNIZIONE PER CERNIERA VETRO-MURO mt.2	AG411	6-8	1	-
 GUARNIZIONE PER CERNIERA VETRO-VETRO mt.2	AG140	6-8	1	-
 GUARNIZIONE MAGNETICA mt.2	AG422 A	6-8	2	-

VARIANTI AL KIT BASE

Indicare la variante o combinazione di varianti desiderata, in sostituzione ai componenti il kit base

COD. VAR.	VARIANTI DISPONIBILI	COD. ART.	SP. VET. mm	NR. PZ.
A	 CERNIERA VETRO-VETRO MOD. SPIGOLI RAGG.	900A	6	2
B	 CERNIERA VETRO-VETRO MOD. TUTTO TONDO	900B	6	2
C	 SOLO MORSETTO FISSO MURO-VETRO	C0190	6-8	3
D	 +  MORSETTO MURO-VETRO FISSO	C0190	6-8	3
	 +  PROFILO "U" ALLUM. ANOD. SATIN. H mt. 2	C0196	6-8	2
E	-	INCOLLAGGIO UV ANGOLO 90° (installatore)	-	-
F	 SOLO MORSETTO VETRO-VETRO 90°	C0191	6-8	3
G	 MANIGLIA DOPPIA	C0194	6-8	1
H	 COPPIA POMELLI 1 FORO VET. Ø8	C0195	6-8	1
I	 BARRA STABIL... FISSA MURO-VET. L1200mm completo viterie	C0169	6-8	2
J	 BARRA SNOD. 45° VET.-VET. L230mm	C0166	6-8	1
	 BARRA SNOD. 45° L230mm Vet.-Vet.	C0167	6-8	1
Z	 GUARN. OPZIONALE VET. FISSI/BORDO PIATTO mt.2	AG110	6-8	1

APPLICAZIONE A35 - PREPARAZIONE LASTRE

A35

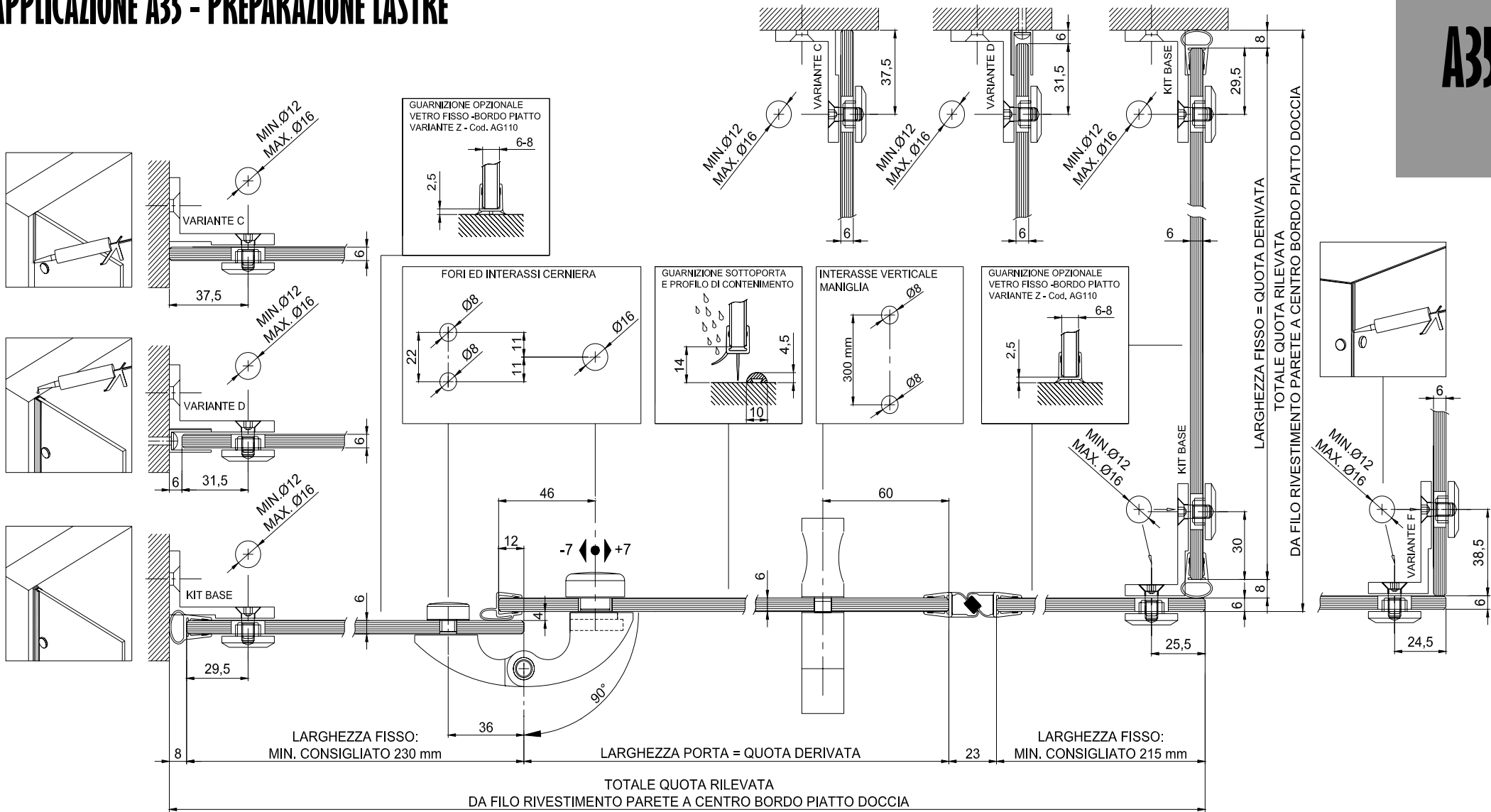





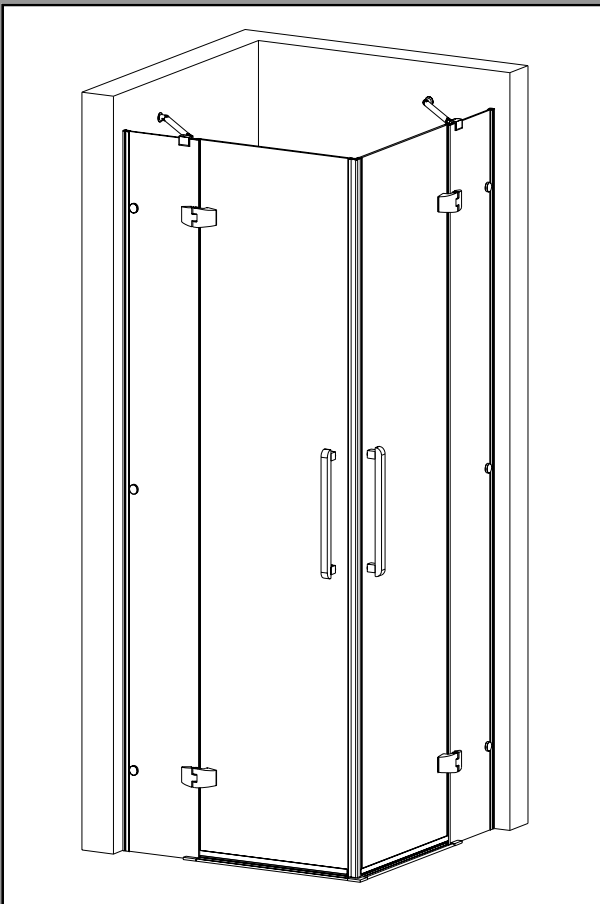

SERIE 900

APPLICAZIONE A36





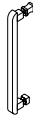
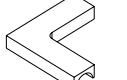
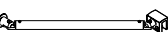





- CABINA IN ANGOLO
FISSO + PORTA IN LINEA SU DUE LATI
- APERTURA ESTERNA 90°
- SPESSORE VETRO: 6 mm
- ALTEZZA CABINA 1800+2000 mm
- PESO MAX. PER COPPIA CERNIERE: 40 Kg.
- LARGHEZZA PORTA MAX 800 mm
- ACCESSORI REVERSIBILI DX/SX
- FINITURA ACCESSORI:
CROMO LUCIDO - ALTRE SU RICHIESTA -

KIT BASE cod. A36

COMPOSIZIONE KIT BASE	COD. ART.	SP. VET. mm	NR. PZ.	VARIANTI DISPON.
 CERNIERA VETRO-VETRO MOD. SQUADRATA	900C	6	4	A / B
 +  MORSETTO MURO-VETRO FISSO	C0190	6-8	6	C D
 GUARNIZIONE VETRO-MURO mt.2	AG411	6-8	2	
 MANIGLIA SINGOLA CON POMELLO INT.	C0193	6-8	2	E F
 PROFILO DI CONTENIMENTO A SILICONARE L= mt.1	M0212	-	2	-
 TERMINALE PER PROFILO DI CONTENIMENTO	M0210	-	2	-
 TERMINALE 90° PER PROFILO DI CONTENIMENTO	M0211	-	1	-
 BARRA SNODATA 45° MURO-VET. L230mm	C0166	6-8	2	-
 GUARNIZIONE SOTTOPORTA mt.2	AG401	6-8	1	-
 GUARNIZIONE PER CERNIERA VETRO-VETRO mt.2	AG140	6-8	2	-
 GUARNIZIONE MAGNETICA mt.2	AG422 A	6-8	1	-
 GUARNIZIONE MAGNETICA mt.2	AG422 B	6-8	1	-

VARIANTI AL KIT BASE

Indicare la variante o combinazione di varianti desiderata, in sostituzione ai componenti il kit base

COD. VAR.	VARIANTI DISPONIBILI	COD. ART.	SP. VET. mm	NR. PZ.
A	 CERNIERA VETRO-VETRO MOD. SPIGOLI RAGG.	900A	6	4
B	 CERNIERA VETRO-VETRO MOD. TUTTO TONDO	900B	6	4
C	 SOLO MORSETTO FISSO MURO-VETRO	C0190	6-8	6
D	 +  MORSETTO MURO-VETRO FISSO	C0190	6-8	6
	 PROFILO "U" ALLUM. ANOD. SATIN. H mt. 2	C0196	6-8	2
E	 MANIGLIA DOPPIA	C0194	6-8	2
F	 COPPIA POMELLI 1 FORO VET. Ø8	C0195	6-8	2
Z	 GUARN. OPZIONALE VET. FISSI/BORDO PIATTO mt.2	AG110	6-8	1

APPLICAZIONE A36 - PREPARAZIONE LASTRE

A36

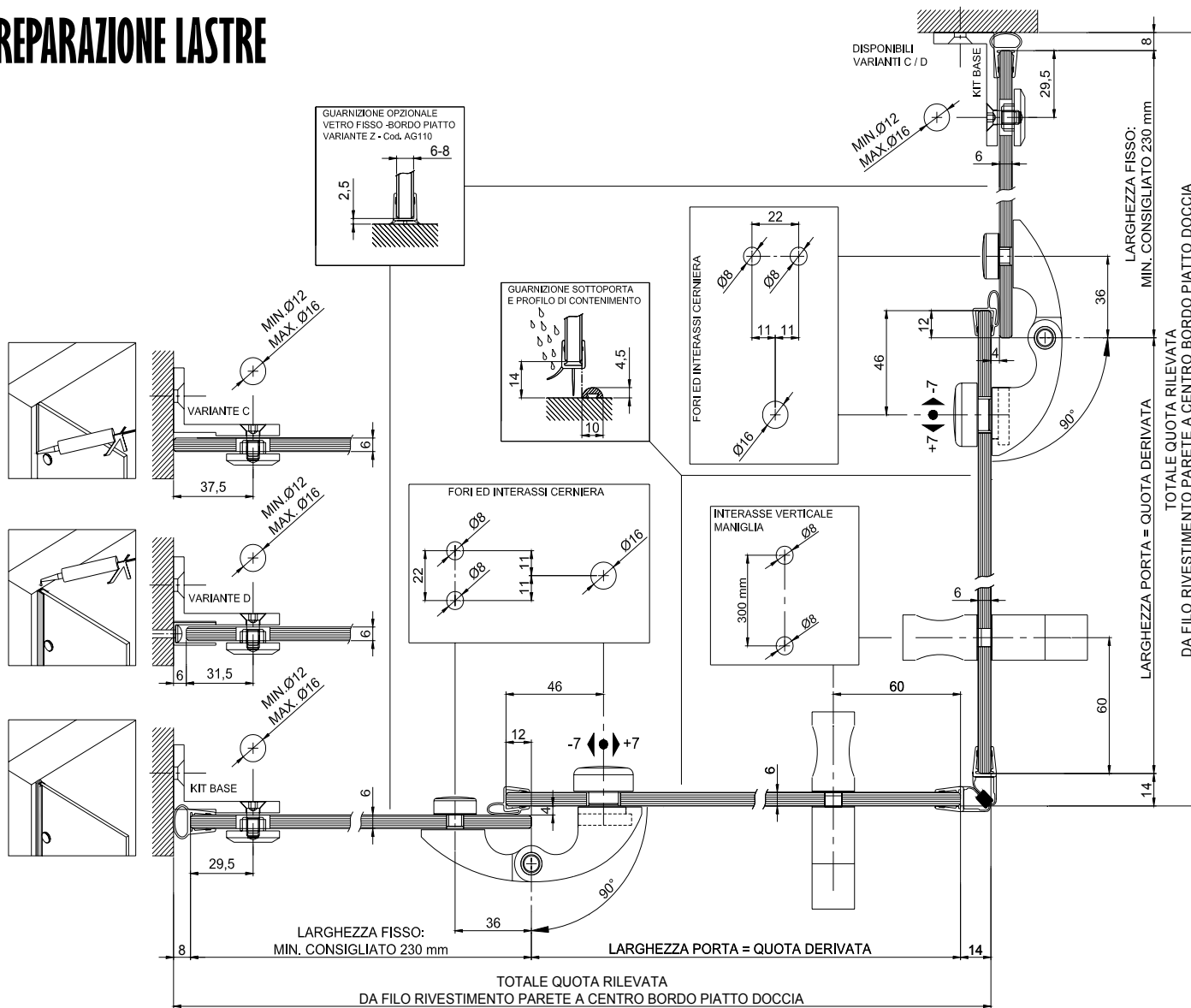

SERIE 900

TECHNOGLASS®

Technoglass s.r.l.

Via A. Volta 53/a - 25065 Lumezzane (Brescia) Italy

Tel. +39 030 8971735 Fax +39 030 87 25 37

e-mail: technoglass@smmoretti.it

www.technoglass-hinges.com